

LO-LINX SWING	GREEN ACT.	WHITE COM.	YELLOW SAF.	BLUE STALL	BROWN STAL COM.
BESAM 300	13	12	11	15, 17	16, 18
BESAM M/P	3	4	9	5	13
DOM	YELLOW	GREY	BLUE	PURPLE	GREY
GT 300/400	BLACK	RED	WHITE	WHITE	RED
GT MAG	6 BLACK	5 RED	4 WHITE	3 VIOLET	5 RED
HORTON 490	2	3, 6, 8	4	10	3, 6, 8
HUNTER	ACT.	RTN	SAF. 1	SAF. 2	RTN
KM K	GREEN	WHITE	RED	YELLOW	WHITE
STANLEY "L"	ORANGE	YELLOW	RED	BLUE	YELLOW
STANLEY M/P	2	18	7	7	18
STANLEY 521	TB4-5	TB4-4	TB4-8	TB4-10	TB4-9
TORMAX TDA	2	1, 3, 6, 8	8 & 9	7	1, 3, 6, 8

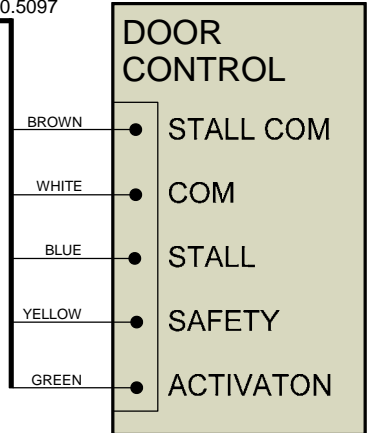
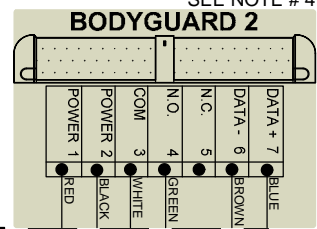
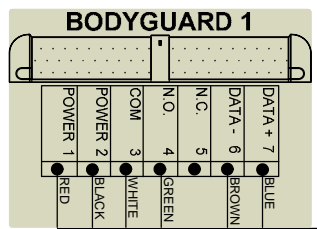
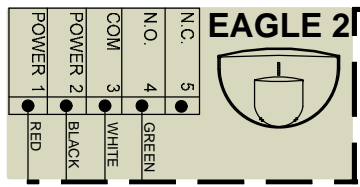
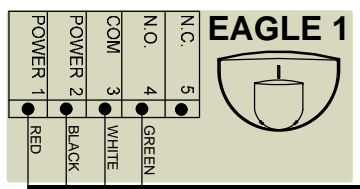
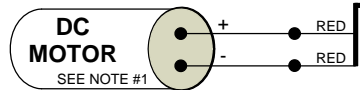
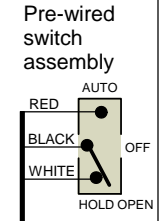
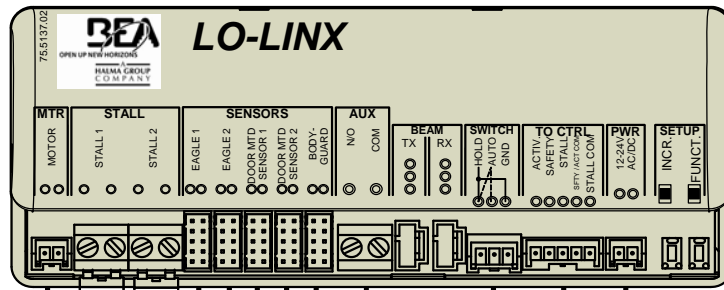

LO-LINX MOTOR HARNESS p/n: 20.5076

LO-LINX EAGLE HARNESS p/n: 20.5096

SEE NOTE # 4

LO-LINX SUPERSCAN HARNESS p/n: 70.5071

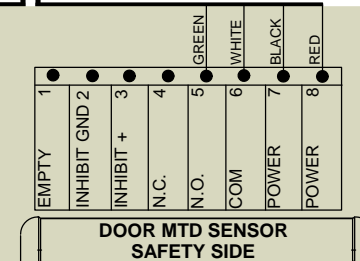
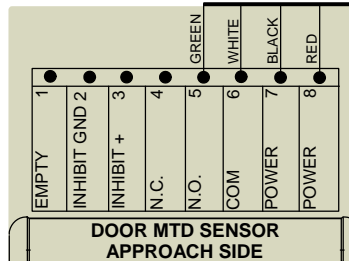
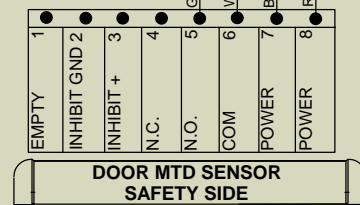
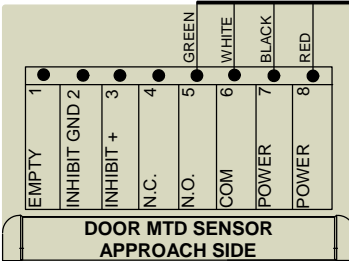

- NOTES:
1. MOTOR CONNECTION IS TIED IN PARALLEL TO EXISTING MOTOR LEADS. NO RESPECT TO PALARITY IS REQUIRED.
 2. EXTERNAL SWITCHES ARE REQUIRED IF INHIBIT DESIRED AT SWING SIDE SUPERSCANS, SWITCH OPENS UPON INHIBIT POINT.
 3. THE KNOWING ACT SWITCH IS CONNECTED AT THE AUX INPUT AND CAN BE ANY DRY CONTACT DEVICE SUCH AS A PUSHPLATE, CARD READER, ETC. THE AUX INPUT IS REQUIRED FOR ALL INITIAL ACTIVATION WHEN FUNCTION 'FA' ON THE LO-LINX IS SET TO '01'.
 4. THE SECOND BODYGUARD AND EAGLE ARE PRIMARILY USED IN DUAL-EGRESS APPLICATIONS.

IF AFTER TROUBLESHOOTING A PROBLEM, A SATISFACTORY SOLUTION CANNOT BE ACHIEVED, PLEASE CALL B.E.A., INC. FOR FURTHER ASSISTANCE DURING EASTERN STANDARD TIME AT 1-800-523-2462 FROM 8AM - 5PM. FOR AFTER-HOURS, CALL EAST COAST: 1-866-836-1863 OR 1-800-407-4545 / MID-WEST: 1-888-308-8843 / WEST COAST: 1-888-419-2564. DO NOT LEAVE ANY PROBLEM UNRESOLVED. IF YOU MUST WAIT FOR THE FOLLOWING WORKDAY TO CALL B.E.A., LEAVE THE DOOR INOPERABLE UNTIL SATISFACTORY REPAIRS CAN BE MADE. NEVER SACRIFICE THE SAFE OPERATION OF THE AUTOMATIC DOOR OR GATE FOR AN INCOMPLETE SOLUTION.WEB: WWW.BEASENSORS.COM

BEA
OPEN UP NEW HORIZONS
A HALMA GROUP COMPANY

100 ENTERPRISE DRIVE
PITTSBURGH, PA 15275
PHONE: (412) 249-4100
FAX: (412) 249-4101
EMAIL: www.beasensors.com

TITLE: GENERAL LO-LINX SYSTEM			
SIZE:	DRAWN BY: JED	REV BY: TUC	PART NO: 80.0240.04
A	SCALE: NONE	DATE: 10/15/2007	SHEET 1 OF 1

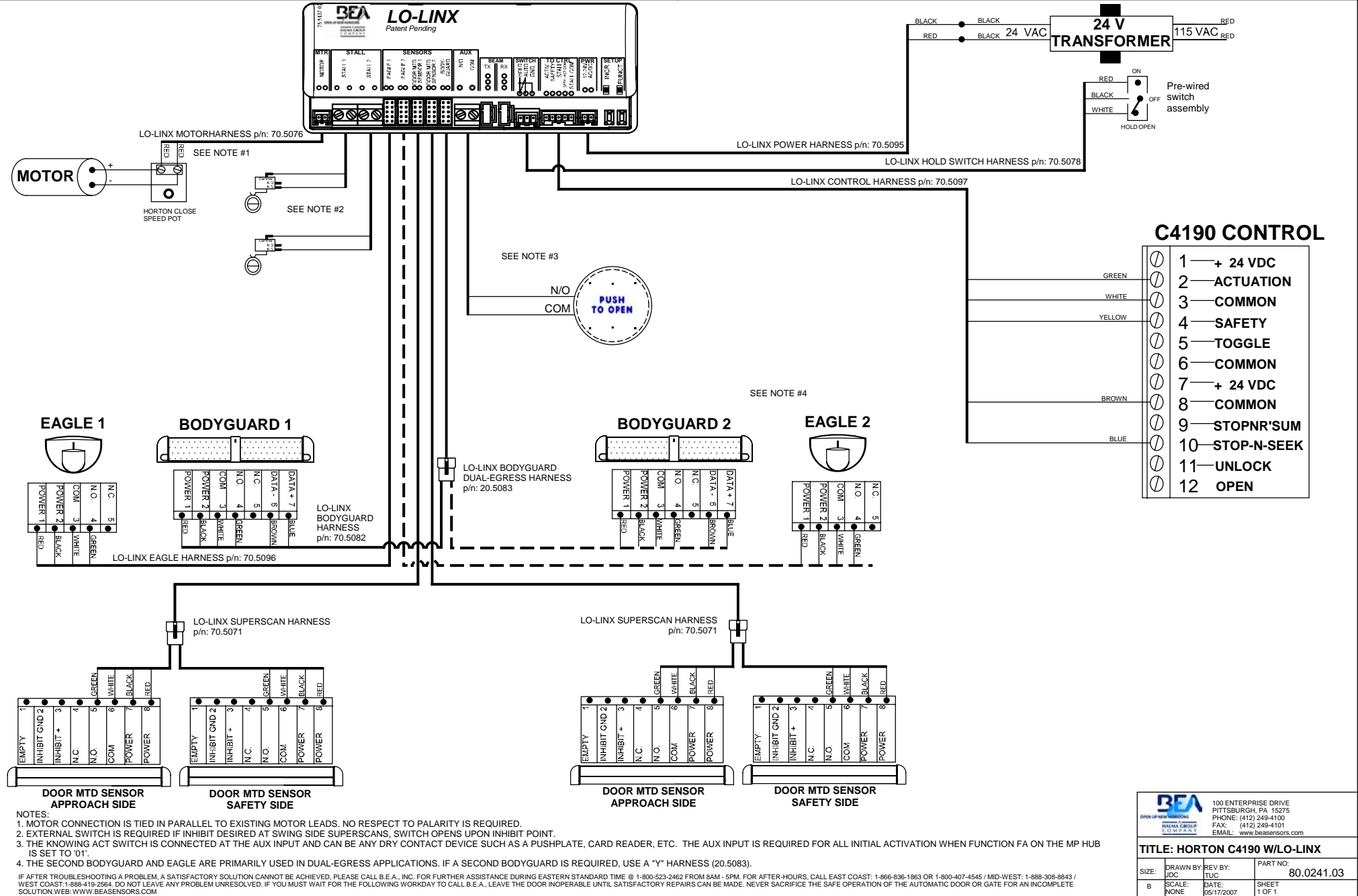

		100 ENTERPRISE DRIVE PITTSBURGH, PA 15275 PHONE: (412) 249-4100 FAX: (412) 249-4101 EMAIL: www.beasensors.com
TITLE: HORTON C4190 W/LO-LINX		
SIZE: LDC	DRAWN BY: TUC	REV BY: TUC
SCALE: NONE	DATE: 05/17/2007	PART NO: 80.0241.03
		SHEET 1 OF 1

LO-LINX SWING	GREEN ACT.	WHITE COM.	YELLOW SAF.	BLUE STALL	BROWN STAL COM.
BESAM 300	13	12	11	15, 17	16, 18
BESAM M/P	3	4	9	5	13
DOM	YELLOW	GREY	BLUE	PURPLE	GREY
GT 300/400	BLACK	RED	WHITE	WHITE	RED
GT MAG	6 BLACK	5 RED	4 WHITE	3 VIOLET	5 RED
HORTON 4100	2	3, 6, 8	4	10	3, 6, 8
HUNTER	ACT.	RTN	SAF. 1	SAF. 2	RTN
KM K	GREEN	WHITE	RED	YELLOW	WHITE
STANLEY "L"	ORANGE	YELLOW	RED	BLUE	YELLOW
STANLEY M/P	2	1, 8	7	7	1, 8
STANLEY 521	TB4-5	TB4-4	TB4-8	TB4-10	TB4-9
TORMAX TDA	2	1, 3, 6, 8	8 & 9	7	1, 3, 6, 8

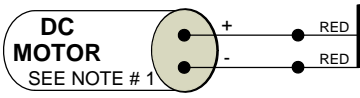
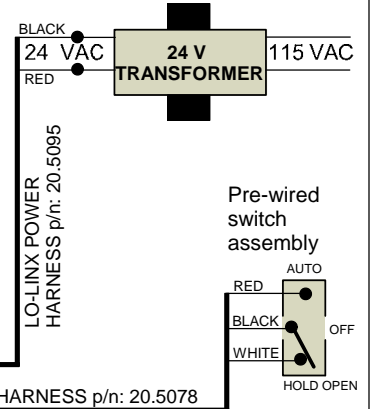
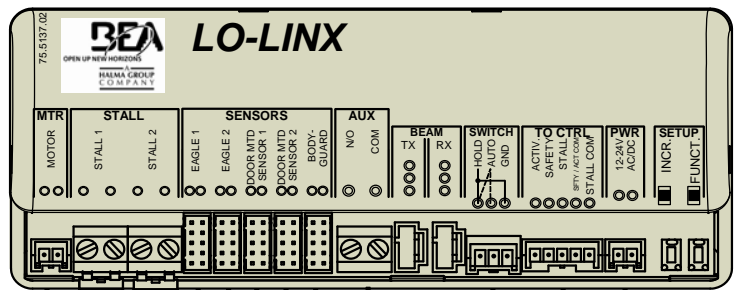

LO-LINX MOTOR HARNESS p/n: 20.5076

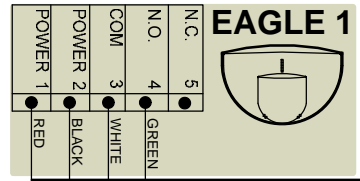

LO-LINX EAGLE HARNESS p/n: 20.5096

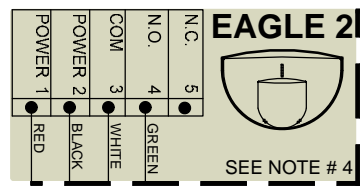

SEE NOTE # 4

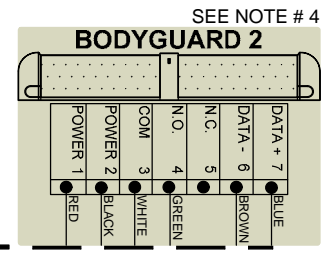
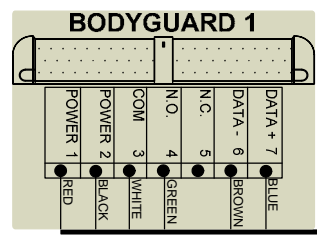

LO-LINX SUPERSCAN HARNESS p/n: 70.5071

SEE NOTE # 4

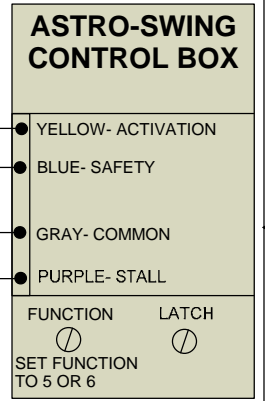
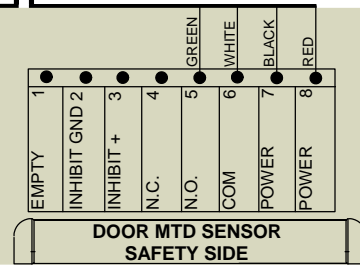
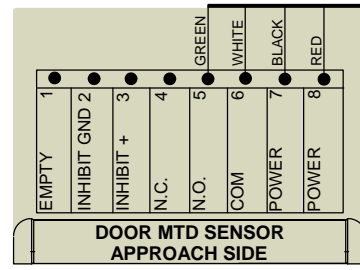
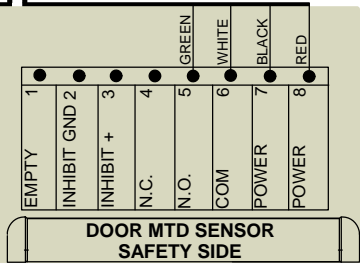
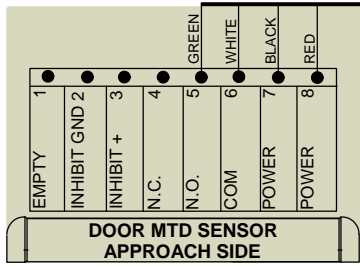

NOTES:
 1. MOTOR CONNECTION IS TIED IN PARALLEL TO EXISTING MOTOR LEADS. NO RESPECT TO PALARITY IS REQUIRED.
 2. EXTERNAL SWITCHES ARE REQUIRED IF INHIBIT DESIRED AT SWING SIDE SUPERSCANS, SWITCH OPENS UPON INHIBIT POINT.
 3. THE KNOWING ACT SWITCH IS CONNECTED AT THE AUX INPUT AND CAN BE ANY DRY CONTACT DEVICE SUCH AS A PUSHPLATE, CARD READER, ETC. THE AUX INPUT IS REQUIRED FOR ALL INITIAL ACTIVATION WHEN FUNCTION 'FA' ON THE LO-LINX IS SET TO '01'.
 4. THE SECOND BODYGUARD AND EAGLE ARE PRIMARILY USED IN DUAL-EGRESS APPLICATIONS. ENSURE BODYGUARD RELAY VALUE IS SET TO 2.

IF AFTER TROUBLESHOOTING A PROBLEM, A SATISFACTORY SOLUTION CANNOT BE ACHIEVED, PLEASE CALL B.E.A., INC. FOR FURTHER ASSISTANCE DURING EASTERN STANDARD TIME AT 1-800-523-2462 FROM 8AM - 5PM. FOR AFTER-HOURS, CALL EAST COAST: 1-866-836-1863 OR 1-800-407-4545 / MID-WEST: 1-888-308-8843 / WEST COAST: 1-888-419-2564. DO NOT LEAVE ANY PROBLEM UNRESOLVED. IF YOU MUST WAIT FOR THE FOLLOWING WORKDAY TO CALL B.E.A., LEAVE THE DOOR INOPERABLE UNTIL SATISFACTORY REPAIRS CAN BE MADE. NEVER SACRIFICE THE SAFE OPERATION OF THE AUTOMATIC DOOR OR GATE FOR AN INCOMPLETE SOLUTION.WEB: WWW.BEASENSORS.COM

100 ENTERPRISE DRIVE
 PITTSBURGH, PA 15275
 PHONE: (412) 249-4100
 FAX: (412) 249-4101
 EMAIL: www.beasensors.com

TITLE: DOROMATIC LO-LINX SYSTEM

SIZE: A	DRAWN BY: JED	REV BY: TUC	PART NO: 80.0242.04
SCALE: NONE	DATE: 10/15/2007	SHEET 1 OF 1	

LO-LINX SWING	GREEN ACT.	WHITE COM.	YELLOW SAF.	BLUE STALL	BROWN STAL COM.
BESAM 300	13	12	11	15, 17	16, 18
BESAM M/P	3	4	9	5	13
DOM	YELLOW	GREY	BLUE	PURPLE	GREY
GT 300/400	BLACK	RED	WHITE	WHITE	RED
GT MAG	6 BLACK	5 RED	4 WHITE	3 VIOLET	5 RED
HORTON 4190	2	3, 6, 8	4	10	3, 6, 8
HUNTER	ACT.	RTN	SAF. 1	SAF. 2	RTN
KM K	GREEN	WHITE	RED	YELLOW	WHITE
STANLEY "L"	ORANGE	YELLOW	RED	BLUE	YELLOW
STANLEY M/P	2	1, 8	7	7	1, 8
STANLEY 521	TB4-5	TB4-4	TB4-8	TB4-10	TB4-9
TORMAX TDA	2	1, 3, 6, 8	8 & 9	7	1, 3, 6, 8

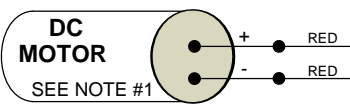
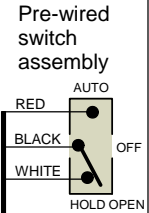
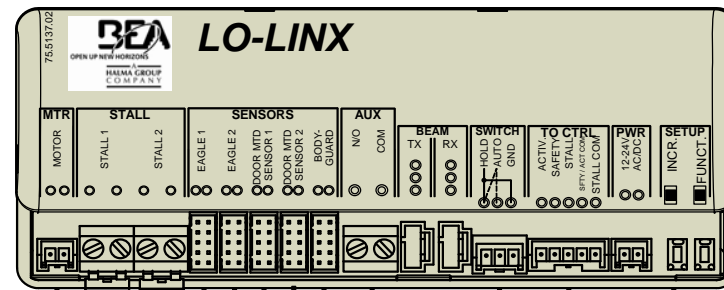

LO-LINX MOTOR HARNESS p/n: 20.5076

SEE NOTE #2

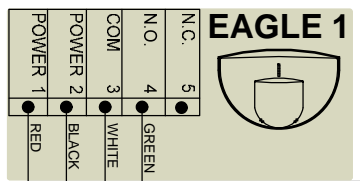

LO-LINX EAGLE HARNESS p/n: 20.5096

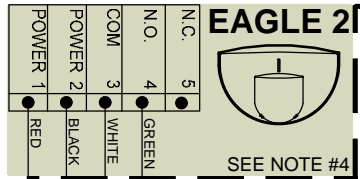

SEE NOTE #4

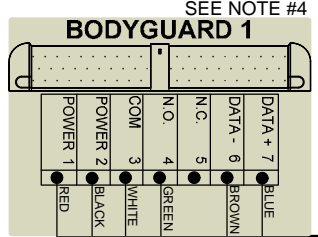

SEE NOTE #4

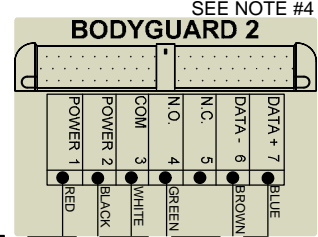

SEE NOTE #4

LO-LINX SUPERSCAN HARNESS p/n: 70.5071

LO-LINX CONTROL HARNESS p/n: 20.5097

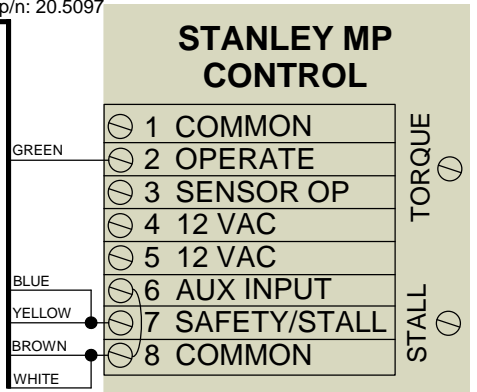

SEE NOTE #5

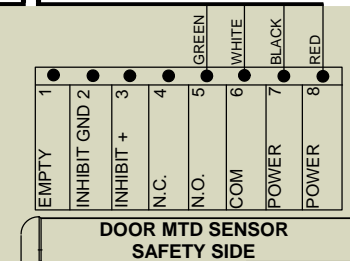
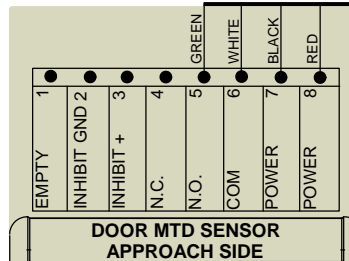
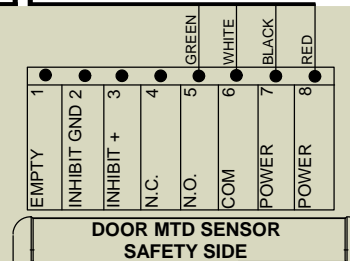
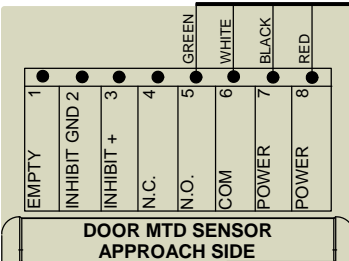

- NOTES:
1. MOTOR CONNECTION IS TIED IN PARALLEL TO EXISTING MOTOR LEADS. NO RESPECT TO POLARITY IS REQUIRED.
 2. EXTERNAL SWITCHES ARE REQUIRED IF INHIBIT IS DESIRED AT SWING SIDE SUPERSCANS, SWITCH OPENS UPON INHIBIT POINT. IF USING MAGIC FORCE, AUX. CAM SWITCH 4 CAN BE USE TO INHIBIT. MAGIC SWING BREAKOUT SWITCHES CAN BE USED IF THEY ARE NOT NEEDED FOR BREAKOUT.
 3. THE KNOWING ACT SWITCH IS CONNECTED AT THE AUX INPUT AND CAN BE ANY DRY CONTACT DEVICE SUCH AS A PUSHPLATE, CARD READER, ETC. THE AUX INPUT IS REQUIRED FOR ALL INITIAL ACTIVATION WHEN FUNCTION 'FA' ON THE LO-LINX IS SET TO '01'.
 4. THE SECOND BODYGUARD AND EAGLE ARE PRIMARILY USED IN DUAL-EGRESS APPLICATIONS. ENSURE BODYGUARD RELAY VALUE IS SET TO 2.
 5. INSERTING A JUMPER ON THE CONTROL TERMINAL # 6 & 8 MAY BE NECESSARY IF NO BREAKOUT SWITCHES ARE ENABLED.

Do not leave problems unresolved. If a satisfactory solution cannot be achieved after troubleshooting a problem, please call B.E.A., Inc. If you must wait for the following workday to call B.E.A., leave the door inoperable until satisfactory repairs can be made. Never sacrifice the safe operation of the automatic door or gate for an incomplete solution. During EST 8am - 5pm call B.E.A., @ 800-523-2462. After 5pm EST all 866-249-7937 or 866-836-1863. After 5pm CST call 800-407-4545 or 888-308-8843. After 5pm MST or PST call 888-419-2564. Ensure compliance with current applicable standards. i.e. ANSI 156.10.

BEA
OPEN UP NEW HORIZONS
HALMA GROUP COMPANY

100 ENTERPRISE DRIVE
PITTSBURGH, PA 15275
PHONE: (412) 249-4100
FAX: (412) 249-4101
EMAIL: www.beasensors.com

TITLE: LO-LINX SYSTEM
STANLEY MP/HDL CONTROL

SIZE: A	DRAWN BY: JED	REV BY: TUC	PART NO: 80.0243.04
SCALE: NONE	DATE: 10/15/2007	SHEET 1 OF 1	

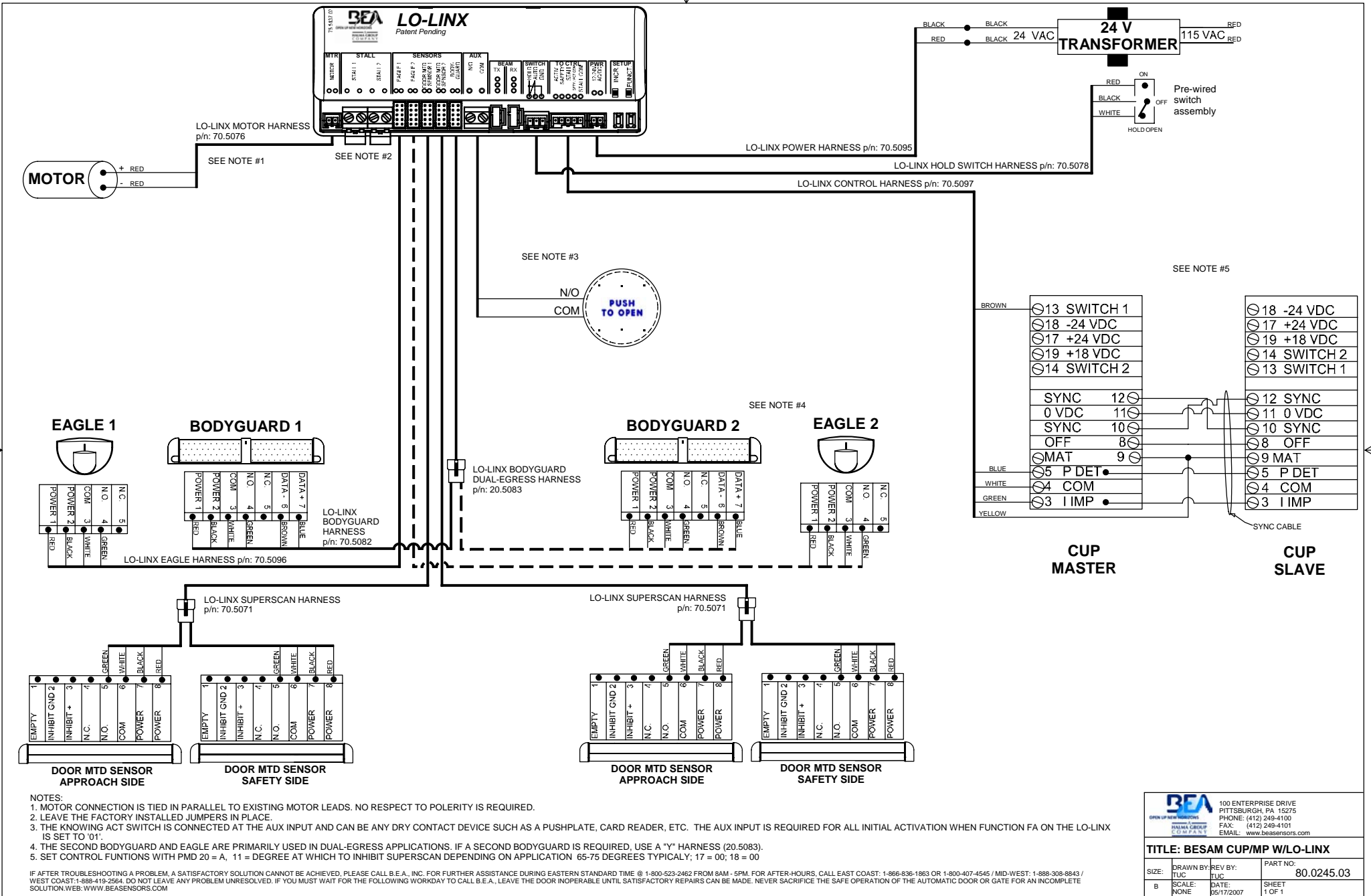

- NOTES:**
1. MOTOR CONNECTION IS TIED IN PARALLEL TO EXISTING MOTOR LEADS. NO RESPECT TO POLARITY IS REQUIRED.
 2. LEAVE THE FACTORY INSTALLED JUMPERS IN PLACE.
 3. THE KNOWING ACT SWITCH IS CONNECTED AT THE AUX INPUT AND CAN BE ANY DRY CONTACT DEVICE SUCH AS A PUSHPLATE, CARD READER, ETC. THE AUX INPUT IS REQUIRED FOR ALL INITIAL ACTIVATION WHEN FUNCTION FA ON THE LO-LINX IS SET TO '01'.
 4. THE SECOND BODYGUARD AND EAGLE ARE PRIMARILY USED IN DUAL-EGRESS APPLICATIONS. IF A SECOND BODYGUARD IS REQUIRED, USE A "Y" HARNESS (20.5083).
 5. SET CONTROL FUNCTIONS WITH PMD 20 = A, 11 = DEGREE AT WHICH TO INHIBIT SUPERSCAN DEPENDING ON APPLICATION 65-75 DEGREES TYPICAL; 17 = 00; 18 = 00

IF AFTER TROUBLESHOOTING A PROBLEM, A SATISFACTORY SOLUTION CANNOT BE ACHIEVED, PLEASE CALL B.E.A., INC. FOR FURTHER ASSISTANCE DURING EASTERN STANDARD TIME @ 1-800-523-2462 FROM 8AM - 5PM. FOR AFTER-HOURS, CALL EAST COAST: 1-866-836-1863 OR 1-800-407-4545 / MID-WEST: 1-888-308-8843 / WEST COAST: 1-888-419-2564. DO NOT LEAVE ANY PROBLEM UNRESOLVED. IF YOU MUST WAIT FOR THE FOLLOWING WORKDAY TO CALL B.E.A., LEAVE THE DOOR INOPERABLE UNTIL SATISFACTORY REPAIRS CAN BE MADE. NEVER SACRIFICE THE SAFE OPERATION OF THE AUTOMATIC DOOR OR GATE FOR AN INCOMPLETE SOLUTION. WEB: WWW.BEASENSORS.COM

		100 ENTERPRISE DRIVE PITTSBURGH, PA 15275 PHONE: (412) 249-4100 FAX: (412) 249-4101 EMAIL: www.beasensors.com	
		TITLE: BESAM CUP/MP W/LO-LINX	
SIZE: TUC SCALE: NONE	DRAWN BY: TUC DATE: 05/17/2007	REV BY: DATE:	PART NO: 80.0245.03 SHEET 1 OF 1

LO-LINX SWING	GREEN ACT.	WHITE COM.	YELLOW SAF.	BLUE STALL	BROWN STAL COM.
BESAM 300	13	12	11	15, 17	16, 18
BESAM M/P	3	4	9	5	13
DOM	YELLOW	GREY	BLUE	PURPLE	GREY
GT 300/400	BLACK	RED	WHITE	WHITE	RED
GT MAG	6 BLACK	5 RED	4 WHITE	3 VIOLET	5 RED
HORTON 4190	2	3, 6, 8	4	10	3, 6, 8
HUNTER	ACT.	RTN	SAF. 1	SAF. 2	RTN
KM K	GREEN	WHITE	RED	YELLOW	WHITE
STANLEY "L"	ORANGE	YELLOW	RED	BLUE	YELLOW
STANLEY M/P	2	1, 8	7	7	1, 8
STANLEY 521	TB4-5	TB4-4	TB4-8	TB4-10	TB4-9
TORMAX TDA	2	1, 3, 6, 8	8 & 9	7	1, 3, 6, 8

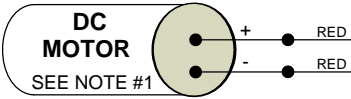
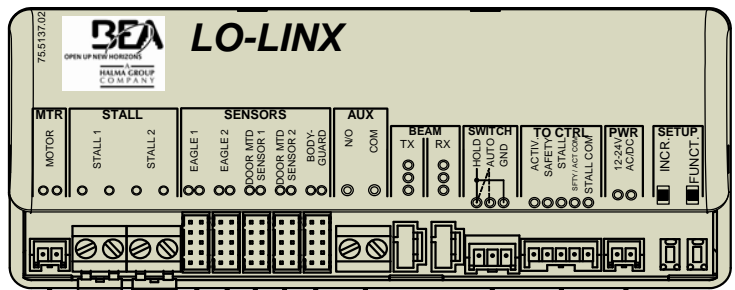

LO-LINX MOTOR HARNESS p/n: 20.5076

SEE NOTE #2

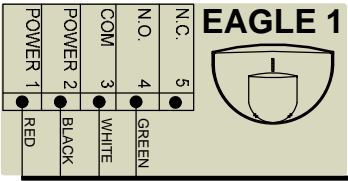

LO-LINX EAGLE HARNESS p/n: 20.5096

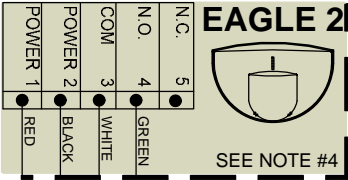

SEE NOTE #4

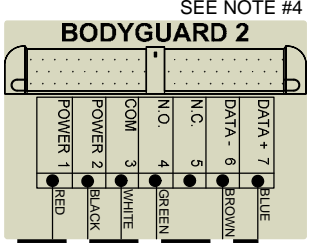
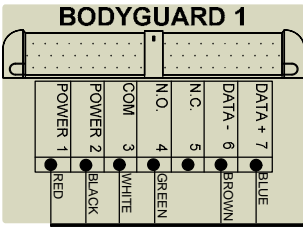

SEE NOTE #4

LO-LINX SUPERSCAN HARNESS p/n: 70.5071

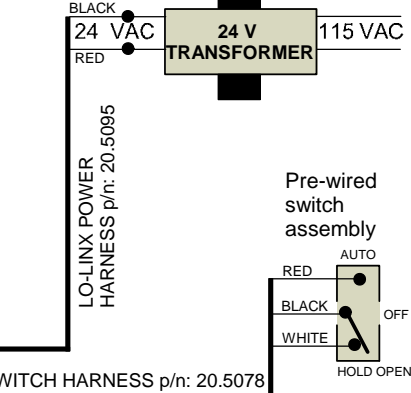
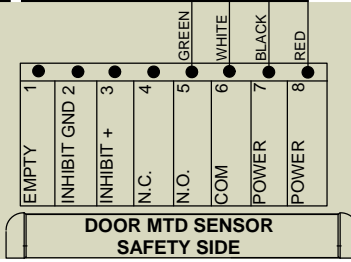
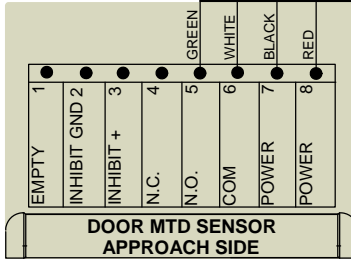
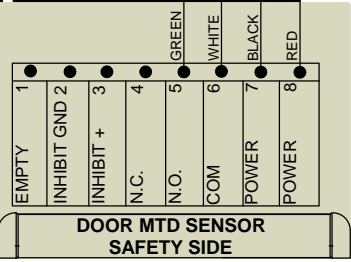
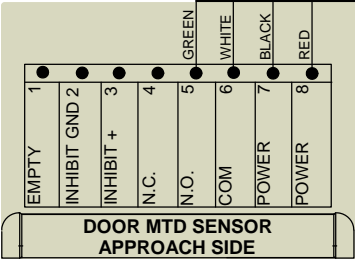

BESAM 300/400 (ETIK) CONTROL

- ⊗ 7 NOT USED
- ⊗ 8 NOT USED
- ⊗ 9 NOT USED
- ⊗ 10 COMMON
- ⊗ 11 SAFETY
- ⊗ 12 COMMON
- ⊗ 13 ACTIVATION
- ⊗ 14 COMMON
- ⊗ 15 STALL
- ⊗ 16 STALL COM.
- ⊗ 17 STALL
- ⊗ 18 STALL COM.

SEE NOTE #5

- NOTES:
- LO-LINX MOTOR HARNESS CONNECTION IS TIED IN PARALLEL TO EXISTING MOTOR LEADS OF 1 MOTOR ONLY. NO RESPECT TO POLARITY IS REQUIRED.
 - EXTERNAL SWITCHES (OR "B" SWITCHES) ARE REQUIRED IF INHIBIT DESIRED AT SWING SIDE SUPERSCANS. SWITCH OPENS UPON INHIBIT POINT.
 - THE KNOWING ACT SWITCH IS CONNECTED AT THE AUX INPUT AND CAN BE ANY DRY CONTACT DEVICE SUCH AS A PUSHPLATE, CARD READER, ETC. THE AUX INPUT IS REQUIRED FOR ALL INITIAL ACTIVATION WHEN FUNCTION FA ON THE LO-LINX IS SET TO '01'.
 - THE SECOND BODYGUARD AND EAGLE ARE PRIMARILY USED IN DUAL-EGRESS APPLICATIONS. IF A SECOND BODYGUARD IS REQUIRED, USE A "Y" HARNESS (20.5083).
 - SET LO-LINX FUNCTION "FS" TO 01. ENSURE BODYGUARD RELAY VALUE IS SET TO 2.

Do not leave problems unresolved. If a satisfactory solution cannot be achieved after troubleshooting a problem, please call B.E.A., Inc. If you must wait for the following workday to call B.E.A., leave the door inoperable until satisfactory repairs can be made. Never sacrifice the safe operation of the automatic door or gate for an incomplete solution. During EST 8am - 5pm call B.E.A., @ 800-523-2462. After 5pm EST all 866-249-7937 or 866-836-1863. After 5pm CST call 800-407-4545 or 888-308-8843. After 5pm MST or PST call 888-419-2564. Ensure compliance with current applicable standards. i.e. ANSI 156.10.

100 ENTERPRISE DRIVE
PITTSBURGH, PA 15275
PHONE: (412) 249-4100
FAX: (412) 249-4101
EMAIL: www.beasensors.com

**TITLE: LO-LINX SYSTEM
BESAM ETIK CONTROL**

SIZE:	DRAWN BY:	REV BY:	PART NO:
A	JED	TUC	80.0246.04
SCALE:	DATE:	DATE:	SHEET
NONE	10/15/2007	10/15/2007	1 OF 1

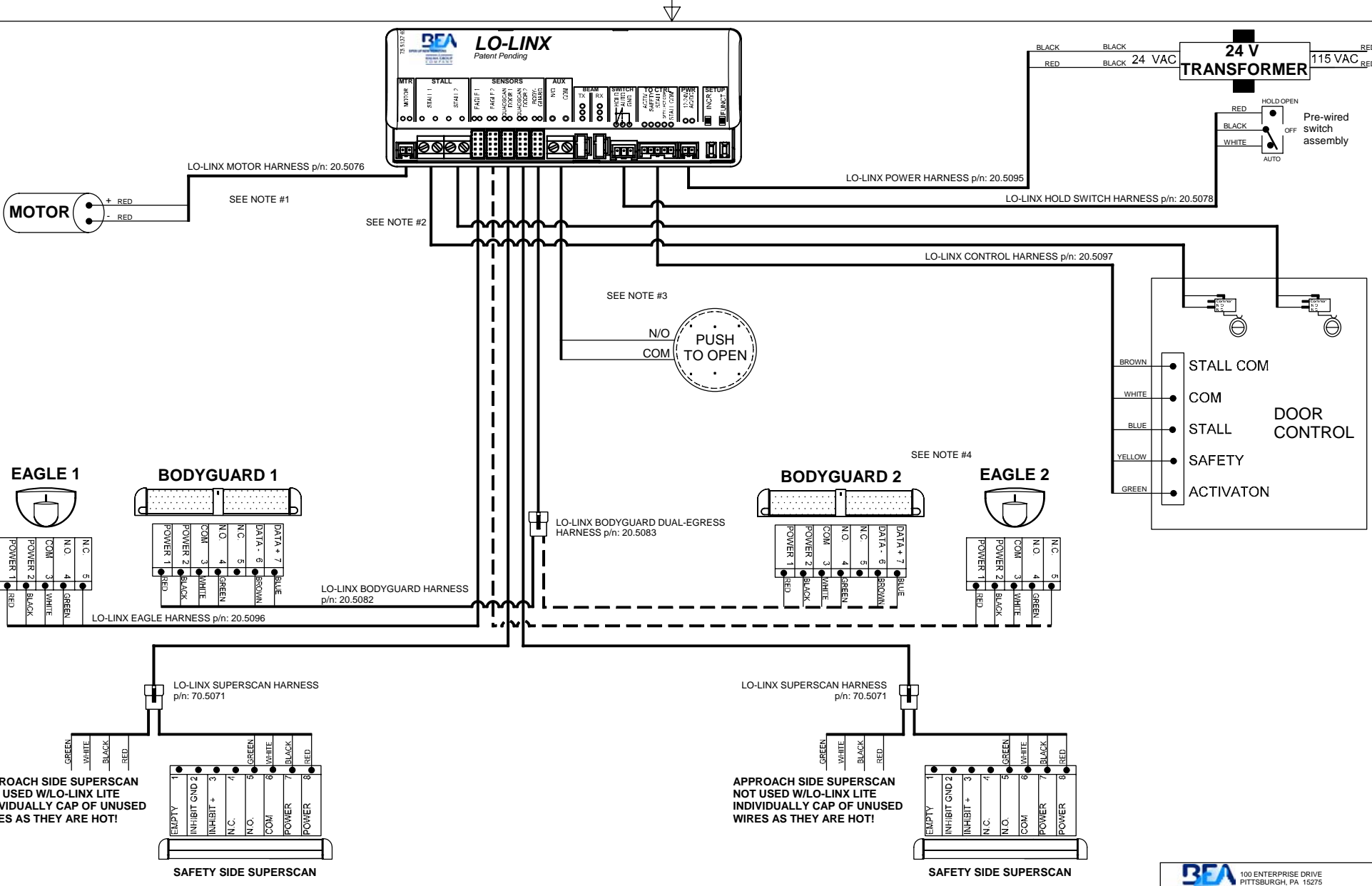

- NOTES:**
1. MOTOR CONNECTION IS TIED IN PARALLEL TO EXISTING MOTOR LEADS. NO RESPECT TO POLARITY IS REQUIRED.
 2. EXTERNAL SWITCHES ARE REQUIRED IF INHIBIT DESIRED AT SWING SIDE SUPERSCANS, SWITCH OPENS UPON INHIBIT POINT.
 3. THE KNOWING ACT SWITCH IS CONNECTED AT THE AUX INPUT AND CAN BE ANY DRY CONTACT DEVICE SUCH AS A PUSHPLATE, CARD READER, ETC. THE AUX INPUT IS REQUIRED FOR ALL INITIAL ACTIVATION WHEN FUNCTION 'FA' ON THE LO-LINX IS SET TO '01'.
 4. THE SECOND BODYGUARD AND EAGLE ARE PRIMARILY USED IN DUAL-EGRESS APPLICATIONS. IF A SECOND BODYGUARD IS REQUIRED, USE A "Y" HARNESS (20.5083).

IF AFTER TROUBLESHOOTING A PROBLEM, A SATISFACTORY SOLUTION CANNOT BE ACHIEVED, PLEASE CALL B.E.A., INC. FOR FURTHER ASSISTANCE DURING EASTERN STANDARD TIME @ 1-800-523-2462 FROM 8AM - 5PM. FOR AFTER-HOURS, CALL EAST COAST: 1-866-836-1863 OR 1-800-407-4545 / MID-WEST: 1-888-308-8843 / WEST COAST: 1-888-419-2564. DO NOT LEAVE ANY PROBLEM UNRESOLVED. IF YOU MUST WAIT FOR THE FOLLOWING WORKDAY TO CALL B.E.A., LEAVE THE DOOR INOPERABLE UNTIL SATISFACTORY REPAIRS CAN BE MADE. NEVER SACRIFICE THE SAFE OPERATION OF THE AUTOMATIC DOOR OR GATE FOR AN INCOMPLETE SOLUTION. WEB: WWW.BEASSENSORS.COM

		100 ENTERPRISE DRIVE PITTSBURGH, PA 15275 PHONE: (412) 249-4100 FAX: (412) 249-4101 EMAIL: www.beasensors.com
TITLE: GENERAL LO-LINX-LITE		
SIZE: LED SCALE: NONE	DRAWN BY: TUC DATE: 05/17/2007	REV BY: PART NO: 80.0273.01 SHEET 1 OF 1

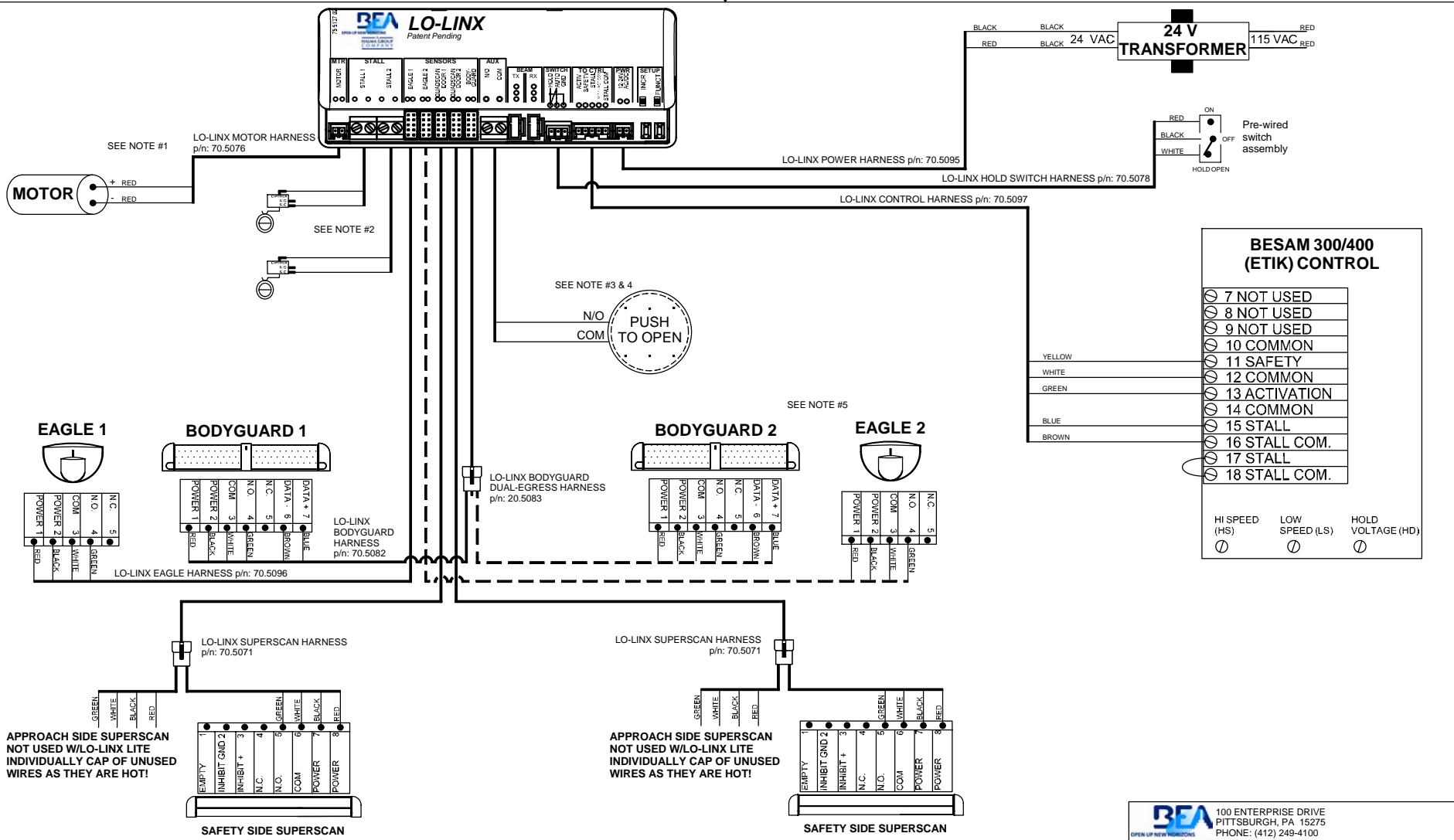

BESAM 300/400 (ETIK) CONTROL

7	NOT USED
8	NOT USED
9	NOT USED
10	COMMON
11	SAFETY
12	COMMON
13	ACTIVATION
14	COMMON
15	STALL
16	STALL COM.
17	STALL
18	STALL COM.

HI SPEED (HS)	LOW SPEED (LS)	HOLD VOLTAGE (HD)
⊖	⊖	⊖

- NOTES:
1. LO-LINX MOTOR HARNESS CONNECTION IS TIED IN PARALLEL TO EXISTING MOTOR LEADS OF 1 MOTOR ONLY. NO RESPECT TO POLARITY IS REQUIRED.
 2. EXTERNAL SWITCHES (OR "B" SWITCHES) ARE REQUIRED IF INHIBIT DESIRED AT SWING SIDE SUPERSCANS. SWITCH OPENS UPON INHIBIT POINT.
 3. THE KNOWING ACT SWITCH IS CONNECTED AT THE AUX INPUT AND CAN BE ANY DRY CONTACT DEVICE SUCH AS A PUSHPLATE, CARD READER, ETC. THE AUX INPUT IS REQUIRED FOR ALL INITIAL ACTIVATION WHEN FUNCTION FA ON THE LO-LINX IS SET TO '01'.
 4. SET LO-LINX FUNCTION 'FS' TO 01.
 5. THE SECOND BODYGUARD AND EAGLE ARE PRIMARILY USED IN DUAL-EGRESS APPLICATIONS. IF A SECOND BODYGUARD IS REQUIRED, USE A "Y" HARNESS (20.5083).

IF AFTER TROUBLESHOOTING A PROBLEM, A SATISFACTORY SOLUTION CANNOT BE ACHIEVED, PLEASE CALL B.E.A., INC. FOR FURTHER ASSISTANCE DURING EASTERN STANDARD TIME @ 1-800-523-2482 FROM 8AM - 5PM. FOR AFTER-HOURS, CALL EAST COAST: 1-866-636-1863 OR 1-800-407-4545 / MID-WEST: 1-888-308-8843 / WEST COAST: 1-888-419-2564. DO NOT LEAVE ANY PROBLEM UNRESOLVED. IF YOU MUST WAIT FOR THE FOLLOWING WORKDAY TO CALL B.E.A., LEAVE THE DOOR INOPERABLE UNTIL SATISFACTORY REPAIRS CAN BE MADE. NEVER SACRIFICE THE SAFE OPERATION OF THE AUTOMATIC DOOR OR GATE FOR AN INCOMPLETE SOLUTION. WEB: WWW.BEASENSORS.COM

BEA 100 ENTERPRISE DRIVE
 PITTSBURGH, PA 15275
 PHONE: (412) 249-4100
 FAX: (412) 249-4101
 EMAIL: www.beasensors.com

TITLE: BESAM SWINGMASTER 300/400 ETIK CONTROL W/LO-LINX-LITE

SIZE: B	DRAWN BY: JED	REV BY: TUC	PART NO: 80.0274.01
SCALE: NONE	DATE: 05/17/2007	SHEET: 1 OF 1	

LO-LINX SWING	GREEN ACT.	WHITE COM.	YELLOW SAF.	BLUE STALL	BROWN STAL COM.
BESAM 300	13	12	11	15, 17	16, 18
BESAM M/P	3	4	9	5	13
DOM	YELLOW	GREY	BLUE	PURPLE	GREY
GT 300/400	BLACK	RED	WHITE	WHITE	RED
GT MAG	6 BLACK	5 RED	4 WHITE	3 VIOLET	5 RED
HORTON 4190	2	3, 6, 8	4	10	3, 6, 8
HUNTER	ACT.	RTN	SAF. 1	SAF. 2	RTN
KM K	GREEN	WHITE	RED	YELLOW	WHITE
STANLEY "L"	ORANGE	YELLOW	RED	BLUE	YELLOW
STANLEY M/P	2	1, 8	7	7	1, 8
STANLEY 521	TB4-5	TB4-4	TB4-8	TB4-10	TB4-9
TORMAX TDA	2	1, 3, 6, 8	8 & 9	7	1, 3, 6, 8

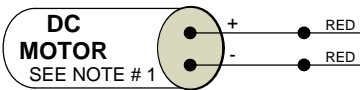
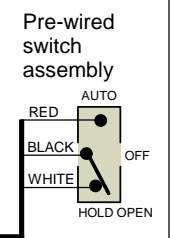
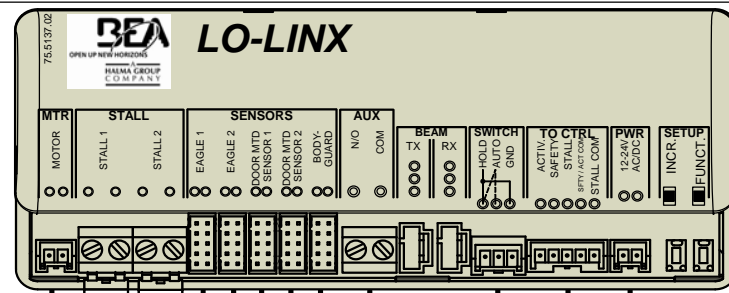

LO-LINX MOTOR HARNESS p/n: 20.5076

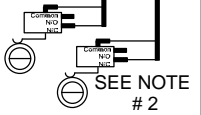

LO-LINX BODYGUARD HARNESS p/n: 20.5082



LO-LINX CONTROL HARNESS p/n: 20.5097

LO-LINX POWER HARNESS p/n: 20.5095

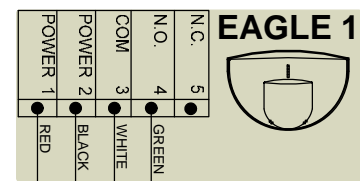

LO-LINX EAGLE HARNESS p/n: 20.5096

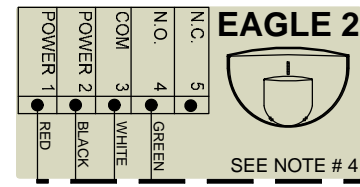

SEE NOTE # 4

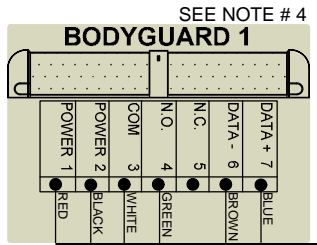

SEE NOTE # 4

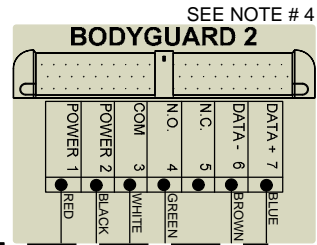

SEE NOTE # 4

LO-LINX SUPERSCAN HARNESS p/n: 70.5071

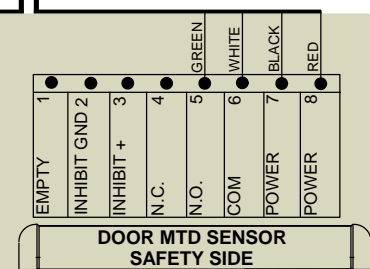
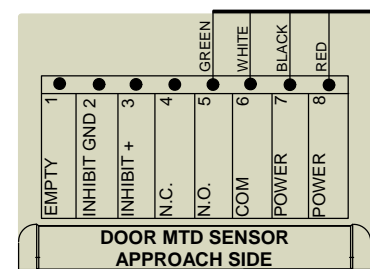
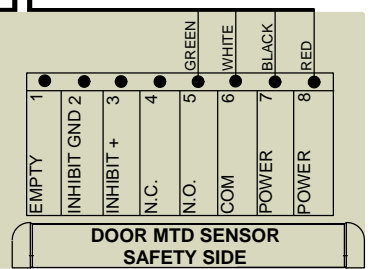
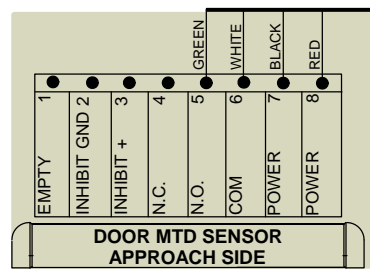
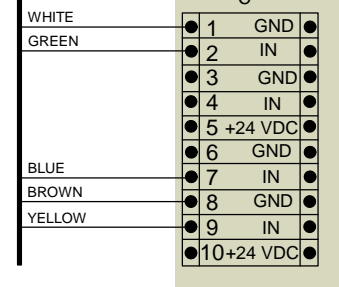

- NOTES:
1. MOTOR CONNECTION IS TIED IN PARALLEL TO EXISTING MOTOR LEADS. NO RESPECT TO PALARITY IS REQUIRED.
 2. EXTERNAL SWITCHES ARE REQUIRED IF INHIBIT DESIRED AT SWING SIDE SUPERSCANS, SWITCH OPENS UPON INHIBIT POINT.
 3. THE KNOWING ACT SWITCH IS CONNECTED AT THE AUX INPUT AND CAN BE ANY DRY CONTACT DEVICE SUCH AS A PUSHPLATE, CARD READER, ETC. THE AUX INPUT IS REQUIRED FOR ALL INITIAL ACTIVATION WHEN FUNCTION 'FA' ON THE LO-LINX IS SET TO '01'.
 4. THE SECOND BODYGUARD AND EAGLE ARE PRIMARILY USED IN DUAL-EGRESS APPLICATIONS. ENSURE BODYGUARD RELAY VALUE IS SET TO 2.

IF AFTER TROUBLESHOOTING A PROBLEM, A SATISFACTORY SOLUTION CANNOT BE ACHIEVED, PLEASE CALL B.E.A., INC. FOR FURTHER ASSISTANCE DURING EASTERN STANDARD TIME AT 1-800-523-2462 FROM 8AM - 5PM. FOR AFTER-HOURS, CALL EAST COAST: 1-866-836-1863 OR 1-800-407-4545 / MID-WEST: 1-888-308-8843 / WEST COAST: 1-888-419-2564. DO NOT LEAVE ANY PROBLEM UNRESOLVED. IF YOU MUST WAIT FOR THE FOLLOWING WORKDAY TO CALL B.E.A., LEAVE THE DOOR INOPERABLE UNTIL FACTORY REPAIRS CAN BE MADE. NEVER SACRIFICE THE SAFE OPERATION OF THE AUTOMATIC DOOR OR GATE FOR AN INCOMPLETE SOLUTION. WEB: WWW.BEASENSORS.COM

BEA
OPEN UP NEW HORIZONS
HALMA GROUP COMPANY

100 ENTERPRISE DRIVE
PITTSBURGH, PA 15275
PHONE: (412) 249-4100
FAX: (412) 249-4101
EMAIL: www.beasensors.com

TITLE: TORMAX TDA- LO-LINX SYSTEM

SIZE: A	DRAWN BY: JED	REV BY: TUC	PART NO: 80.0288.00
SCALE: NONE	DATE: 10/15/2007	SHEET 1 OF 1	

LO-LINX SWING	GREEN ACT.	WHITE COM.	YELLOW SAF.	BLUE STALL	BROWN STAL COM.
BESAM 300	13	12	11	15, 17	16, 18
BESAM M/P	3	4	9	5	13
DOM	YELLOW	GREY	BLUE	PURPLE	GREY
GT 300/400	BLACK	RED	WHITE	WHITE	RED
GT MAG	6 BLACK	5 RED	4 WHITE	3 VIOLET	5 RED
HORTON 4190	2	3, 6, 8	4	10	3, 6, 8
HUNTER	ACT.	RTN	SAF. 1	SAF. 2	RTN
KM K	GREEN	WHITE	RED	YELLOW	WHITE
STANLEY "L"	ORANGE	YELLOW	RED	BLUE	YELLOW
STANLEY M/P	2	1, 8	7	7	1, 8
STANLEY 521	TB4-5	TB4-4	TB4-8	TB4-10	TB4-9
TORMAX TDA	2	1, 3, 6, 8	8 & 9	7	1, 3, 6, 8

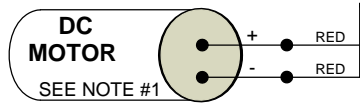
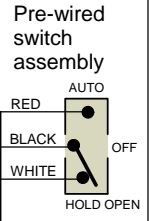
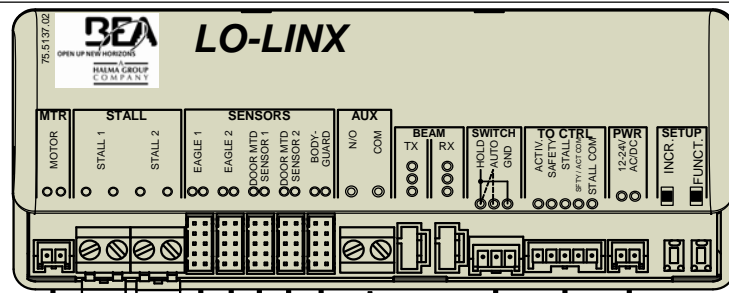

LO-LINX MOTOR HARNESS p/n: 20.5076

SEE NOTE #2

SEE NOTE #3

LO-LINX HOLD SWITCH HARNESS p/n: 20.5078

LO-LINX CONTROL HARNESS p/n: 20.5077

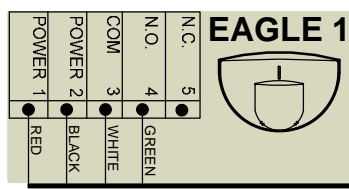

LO-LINX EAGLE HARNESS p/n: 20.5096

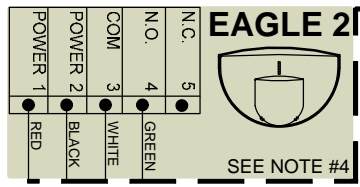

SEE NOTE #4

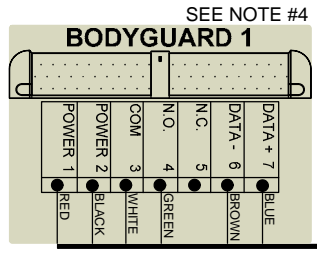

SEE NOTE #4

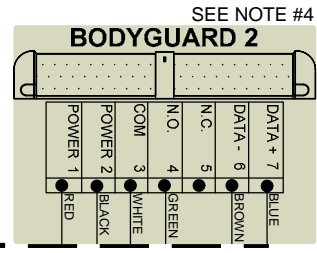

SEE NOTE #4

LO-LINX SUPERSCAN HARNESS p/n: 70.5071

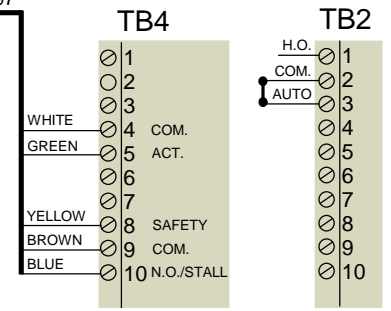

STANLEY 521 CONTROL

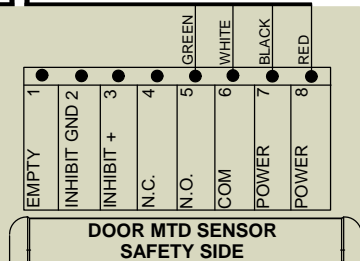
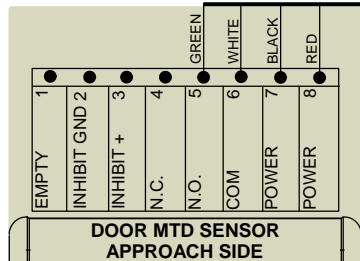
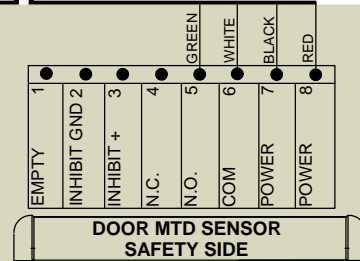
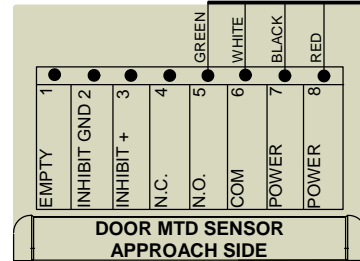

- NOTES:
1. MOTOR CONNECTION IS TIED IN PARALLEL TO EXISTING MOTOR LEADS. NO RESPECT TO PALARITY IS REQUIRED.
 2. EXTERNAL SWITCHES ARE REQUIRED IF INHIBIT DESIRED AT SWING SIDE SUPERSCANS, SWITCH OPENS UPON INHIBIT POINT.
 3. THE KNOWING ACT SWITCH IS CONNECTED AT THE AUX INPUT AND CAN BE ANY DRY CONTACT DEVICE SUCH AS A PUSHPLATE, CARD READER, ETC. THE AUX INPUT IS REQUIRED FOR ALL INITIAL ACTIVATION WHEN FUNCTION 'FA' ON THE LO-LINX IS SET TO '01'.
 4. THE SECOND BODYGUARD AND EAGLE ARE PRIMARILY USED IN DUAL-EGRESS APPLICATIONS. ENSURE BODYGUARD RELAY VALUE IS SET TO 2.

IF AFTER TROUBLESHOOTING A PROBLEM, A SATISFACTORY SOLUTION CANNOT BE ACHIEVED, PLEASE CALL B.E.A., INC. FOR FURTHER ASSISTANCE DURING EASTERN STANDARD TIME AT 1-800-523-2462 FROM 8AM - 5PM. FOR AFTER-HOURS, CALL EAST COAST: 1-866-836-1863 OR 1-800-407-4545 / MID-WEST: 1-888-308-8843 / WEST COAST: 1-888-419-2564. DO NOT LEAVE ANY PROBLEM UNRESOLVED. IF YOU MUST WAIT FOR THE FOLLOWING WORKDAY TO CALL B.E.A., LEAVE THE DOOR INOPERABLE UNTIL SATISFACTORY REPAIRS CAN BE MADE. NEVER SACRIFICE THE SAFE OPERATION OF THE AUTOMATIC DOOR OR GATE FOR AN INCOMPLETE SOLUTION.WEB: WWW.BEASENSORS.COM

BEA
OPEN UP NEW HORIZONS
HALAMA GROUP COMPANY

100 ENTERPRISE DRIVE
PITTSBURGH, PA 15275
PHONE: (412) 249-4100
FAX: (412) 249-4101
EMAIL: www.beasensors.com

TITLE: STANLEY 521 - LO-LINX SYSTEM

SIZE: A	DRAWN BY: JED	REV BY: TUC	PART NO: 80.0287.00
SCALE: NONE	DATE: 10/15/2007	SHEET 1 OF 1	

LO-LINX SWING	GREEN ACT.	WHITE COM.	YELLOW SAF.	BLUE STALL	BROWN STAL COM.
BESAM 300	13	12	11	15, 17	16, 18
BESAM M/P	3	4	9	5	13
DOM	YELLOW	GREY	BLUE	PURPLE	GREY
GT 300/400	BLACK	RED	WHITE	WHITE	RED
GT MAG	6 BLACK	5 RED	4 WHITE	3 VIOLET	5 RED
HORTON 4180	2	3, 6, 8	4	10	3, 6, 8
HUNTER	ACT.	RTN	SAF. 1	SAF. 2	RTN
KM K	GREEN	WHITE	RED	YELLOW	WHITE
STANLEY "L"	ORANGE	YELLOW	RED	BLUE	YELLOW
STANLEY M/P	2	18	7	7	18
STANLEY 521	TB4-5	TB4-4	TB4-8	TB4-10	TB4-9
TORMAX TDA	2	1, 3, 6, 8	8 & 9	7	1, 3, 6, 8

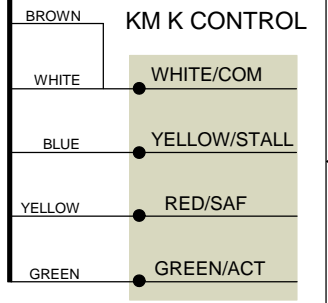
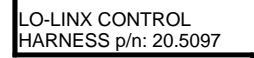
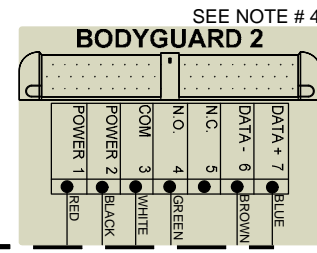
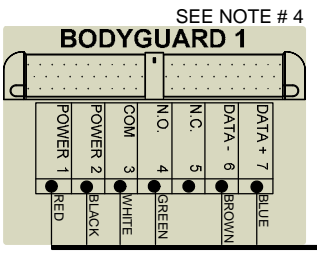
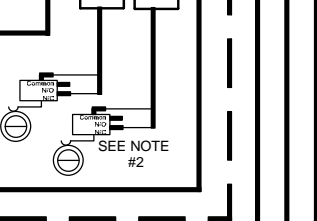
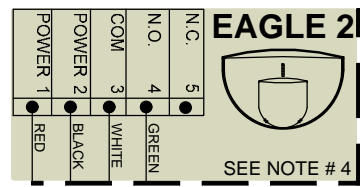
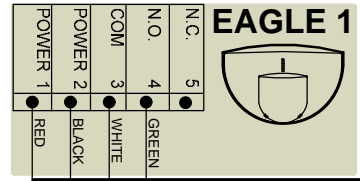
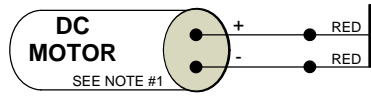
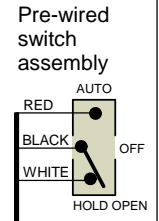
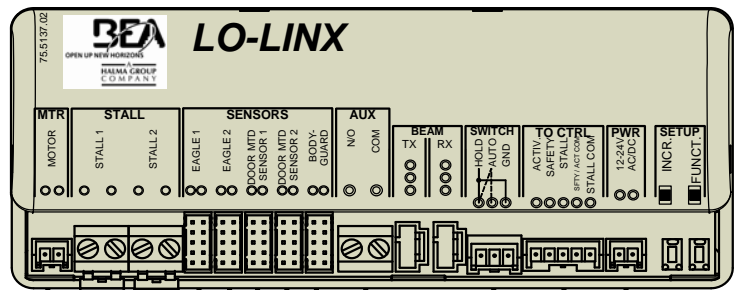

LO-LINX MOTOR HARNESS p/n: 20.5076

LO-LINX EAGLE HARNESS p/n: 20.5096

LO-LINX SUPERSCAN HARNESS p/n: 70.5071

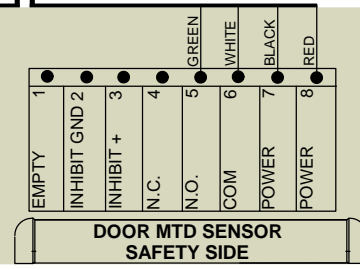
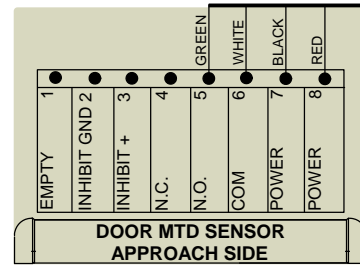
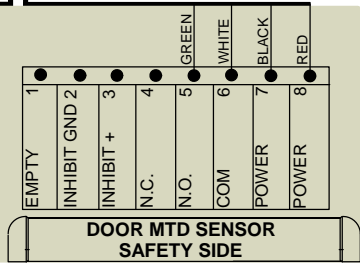
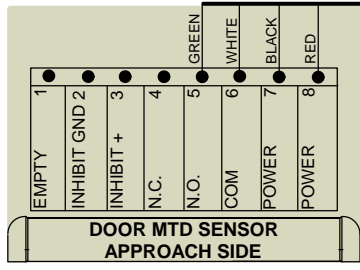

- NOTES:
1. MOTOR CONNECTION IS TIED IN PARALLEL TO EXISTING MOTOR LEADS. NO RESPECT TO PARALITY IS REQUIRED.
 2. EXTERNAL SWITCHES ARE REQUIRED IF INHIBIT DESIRED AT SWING SIDE SUPERSCANS, SWITCH OPENS UPON INHIBIT POINT.
 3. THE KNOWING ACT SWITCH IS CONNECTED AT THE AUX INPUT AND CAN BE ANY DRY CONTACT DEVICE SUCH AS A PUSHPLATE, CARD READER, ETC. THE AUX INPUT IS REQUIRED FOR ALL INITIAL ACTIVATION WHEN FUNCTION 'FA' ON THE LO-LINX IS SET TO '01'.
 4. THE SECOND BODYGUARD AND EAGLE ARE PRIMARILY USED IN DUAL-EGRESS APPLICATIONS. ENSURE BODYGUARD RELAY VALUE IS SET TO 2.

IF AFTER TROUBLESHOOTING A PROBLEM, A SATISFACTORY SOLUTION CANNOT BE ACHIEVED, PLEASE CALL B.E.A., INC. FOR FURTHER ASSISTANCE DURING EASTERN STANDARD TIME AT 1-800-523-2462 FROM 8AM - 5PM. FOR AFTER-HOURS, CALL EAST COAST: 1-866-836-1863 OR 1-800-407-4545 / MID-WEST: 1-888-308-8843 / WEST COAST: 1-888-419-2564. DO NOT LEAVE ANY PROBLEM UNRESOLVED. IF YOU MUST WAIT FOR THE FOLLOWING WORKDAY TO CALL B.E.A., LEAVE THE DOOR INOPERABLE UNTIL SATISFACTORY REPAIRS CAN BE MADE. NEVER SACRIFICE THE SAFE OPERATION OF THE AUTOMATIC DOOR OR GATE FOR AN INCOMPLETE SOLUTION. WEB: WWW.BEASENSORS.COM

BEA
OPEN UP NEW HORIZONS
A HALMA GROUP COMPANY

100 ENTERPRISE DRIVE
PITTSBURGH, PA 15275
PHONE: (412) 249-4100
FAX: (412) 249-4101
EMAIL: www.beasensors.com

TITLE: KM "K" CONTROL
LO-LINX SYSTEM

SIZE: A	DRAWN BY: JED	REV BY: TUC	PART NO: 80.0286.00
SCALE: NONE	DATE: 10/15/2007	SHEET 1 OF 1	

LO-LINX SWING	GREEN ACT.	WHITE COM.	YELLOW SAF.	BLUE STALL	BROWN STAL COM.
BESAM 300	13	12	11	15, 17	16, 18
BESAM M/P	3	4	9	5	13
DOM	YELLOW	GREY	BLUE	PURPLE	GREY
GT 300/400	BLACK	RED	WHITE	WHITE	RED
GT MAG	6 BLACK	5 RED	4 WHITE	3 VIOLET	5 RED
HORTON 490	2	3, 6, 8	4	10	3, 6, 8
HUNTER	ACT.	RTN	SAF. 1	SAF. 2	RTN
KM K	GREEN	WHITE	RED	YELLOW	WHITE
STANLEY "L"	ORANGE	YELLOW	RED	BLUE	YELLOW
STANLEY M/P	2	18	7	7	18
STANLEY 521	TB4-5	TB4-4	TB4-8	TB4-10	TB4-9
TORMAX TDA	2	1, 3, 6, 8	8 & 9	7	1, 3, 6, 8

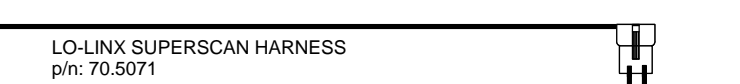
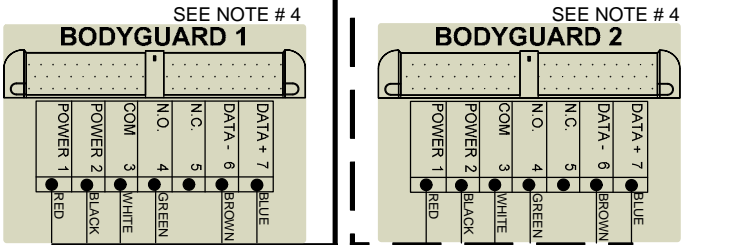
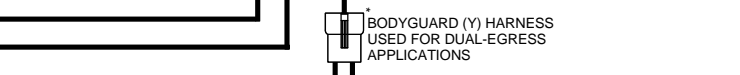
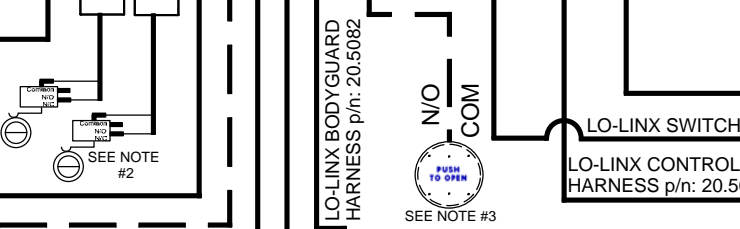
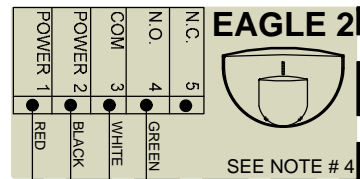
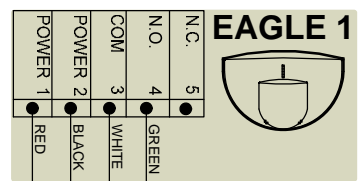
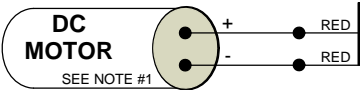
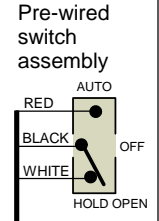
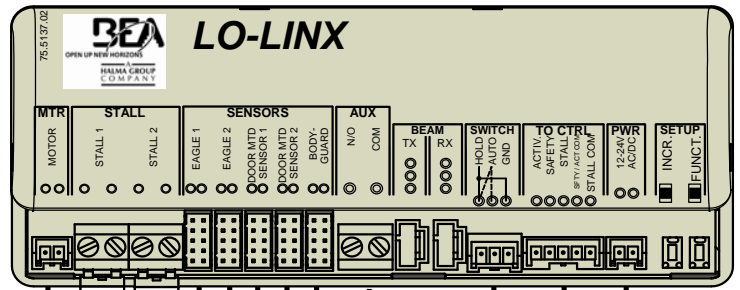

GREEN	Activation
WHITE	RTN
YELLOW	Safety 1
BROWN	RTN
BLUE	Safety 2
	24VAC Out
	24VAC Out
	Ground
	24VAC IN
	24VAC IN

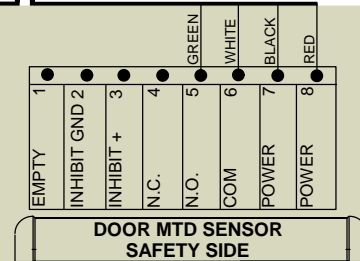
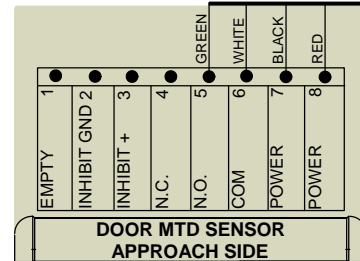
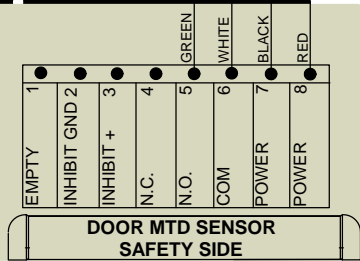
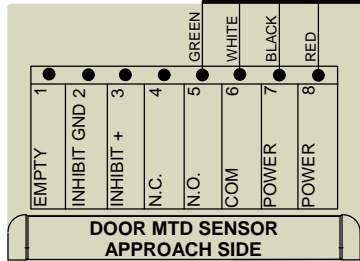

NOTES:

1. MOTOR CONNECTION IS TIED IN PARALLEL TO EXISTING MOTOR LEADS. NO RESPECT TO PARALITY IS REQUIRED.
2. EXTERNAL SWITCHES ARE REQUIRED IF INHIBIT DESIRED AT SWING SIDE SUPERSCAN. SWITCH OPENS UPON INHIBIT POINT.
3. THE KNOWING ACT SWITCH IS CONNECTED AT THE AUX INPUT AND CAN BE ANY DRY CONTACT DEVICE SUCH AS A PUSHPLATE, CARD READER, ETC. THE AUX INPUT IS REQUIRED FOR ALL INITIAL ACTIVATION WHEN FUNCTION 'FA' ON THE LO-LINX IS SET TO '01'.
4. THE SECOND BODYGUARD AND EAGLE ARE PRIMARILY USED IN DUAL-EGRESS APPLICATIONS. ENSURE BODYGUARD RELAY VALUE IS SET TO 2.
5. BEA RECOMMENDS TO USE THE HUNTER SYNC BOARD TO SYNC 2 DOOR CONTROLS FOR A PAIR OR DOUBLE EGRESSES SET OF DOORS.

IF AFTER TROUBLESHOOTING A PROBLEM, A SATISFACTORY SOLUTION CANNOT BE ACHIEVED, PLEASE CALL B.E.A., INC. FOR FURTHER ASSISTANCE DURING EASTERN STANDARD TIME AT 1-800-523-2462 FROM 8AM - 5PM. FOR AFTER-HOURS, CALL EAST COAST: 1-866-836-1863 OR 1-800-407-4545 / MID-WEST: 1-888-308-8843 / WEST COAST: 1-888-419-2564. DO NOT LEAVE ANY PROBLEM UNRESOLVED. IF YOU MUST WAIT FOR THE FOLLOWING WORKDAY TO CALL B.E.A., LEAVE THE DOOR INOPERABLE UNTIL SATISFACTORY REPAIRS CAN BE MADE. NEVER SACRIFICE THE SAFE OPERATION OF THE AUTOMATIC DOOR OR GATE FOR AN INCOMPLETE SOLUTION. WEB: WWW.BEASENSORS.COM

OPEN UP NEW HORIZONS
A HALMA GROUP COMPANY

100 ENTERPRISE DRIVE
PITTSBURGH, PA 15275
PHONE: (412) 249-4100
FAX: (412) 249-4101
EMAIL: www.beasensors.com

TITLE: HUNTER LO-LINX SYSTEM

SIZE: A	DRAWN BY: JED	REV BY: TUC	PART NO: 80.0285.00
SCALE: NONE	DATE: 10/15/2007	SHEET 1 OF 1	

LO-LINX SWING	GREEN ACT.	WHITE COM.	YELLOW SAF.	BLUE STALL	BROWN STAL COM.
BESAM 300	13	12	11	15, 17	16, 18
BESAM M/P	3	4	9	5	13
DOM	YELLOW	GREY	BLUE	PURPLE	GREY
GT 300/400	BLACK	RED	WHITE	WHITE	RED
GT MAG	6 BLACK	5 RED	4 WHITE	3 VIOLET	5 RED
HORTON 4190	2	3, 6, 8	4	10	3, 6, 8
HUNTER	ACT.	RTN	SAF. 1	SAF. 2	RTN
KM K	GREEN	WHITE	RED	YELLOW	WHITE
STANLEY "L"	ORANGE	YELLOW	RED	BLUE	YELLOW
STANLEY M/P	2	1, 8	7	7	1, 8
STANLEY 521	TB4-5	TB4-4	TB4-8	TB4-10	TB4-9
TORMAX TDA	2	1, 3, 6, 8	8 & 9	7	1, 3, 6, 8

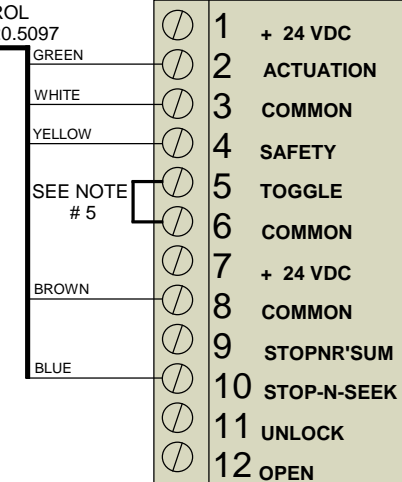
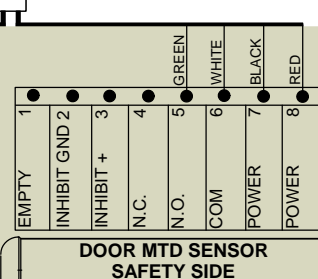
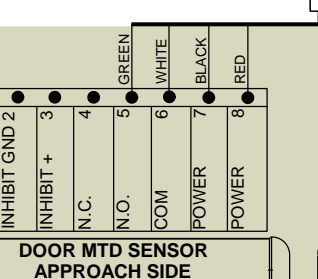
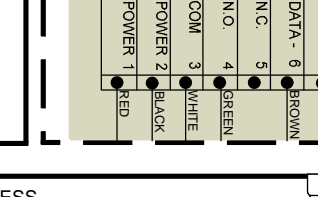
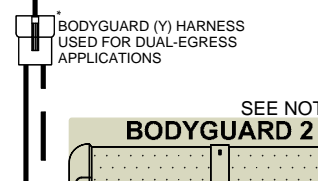
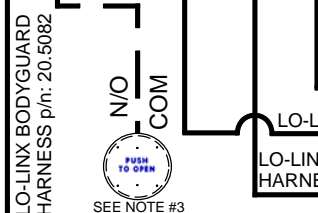
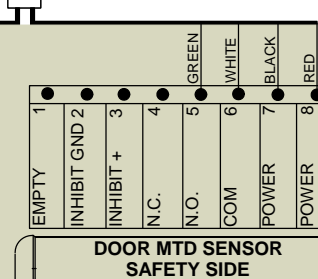
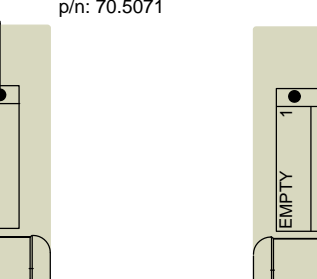
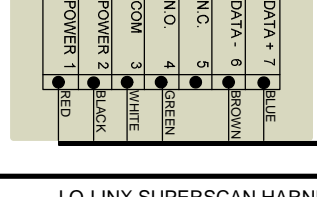
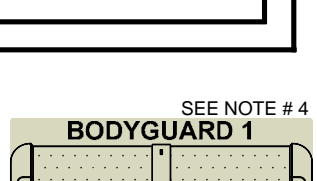
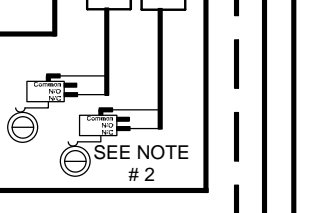
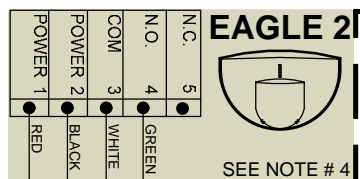
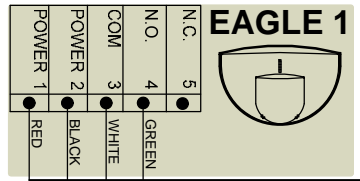
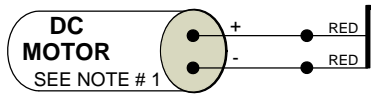
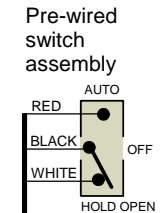
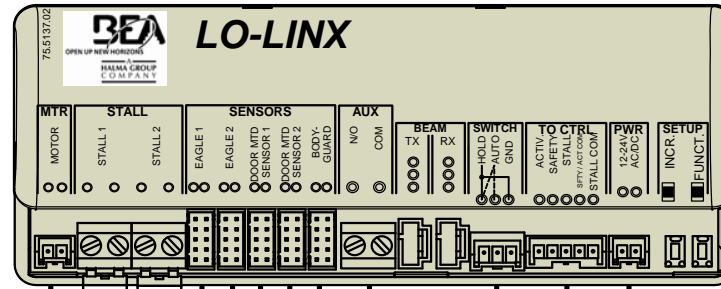

NOTES:

- MOTOR CONNECTION IS TIED IN PARALLEL TO EXISTING MOTOR LEADS. NO RESPECT TO PALARITY IS REQUIRED.
- EXTERNAL SWITCH IS REQUIRED IF INHIBIT DESIRED AT SWING SIDE SUPERSkans, SWITCH OPENS UPON INHIBIT POINT.
- THE KNOWING ACT SWITCH IS CONNECTED AT THE AUX INPUT AND CAN BE ANY DRY CONTACT DEVICE SUCH AS A PUSHPLATE, CARD READER, ETC. THE AUX INPUT IS REQUIRED FOR ALL INITIAL ACTIVATION WHEN FUNCTION "FA" ON THE LO-LINX IS SET TO '01'.
- THE SECOND BODYGUARD AND EAGLE ARE PRIMARILY USED IN DUAL-EGRESS APPLICATIONS. IF A SECOND BODYGUARD IS REQUIRED, USE A "Y" HARNESS (20.5083). ENSURE BODYGUARD RELAY VALUE IS SET TO 2.
- INSERT JUMPER INTO 5 & 6.

IF AFTER TROUBLESHOOTING A PROBLEM, A SATISFACTORY SOLUTION CANNOT BE ACHIEVED, PLEASE CALL B.E.A., INC. FOR FURTHER ASSISTANCE DURING EASTERN STANDARD TIME AT 1-800-523-2462 FROM 8AM - 5PM. FOR AFTER-HOURS, CALL EAST COAST: 1-866-836-1863 OR 1-800-407-4545 / MID-WEST: 1-888-308-8843 / WEST COAST: 1-888-419-2564. DO NOT LEAVE ANY PROBLEM UNRESOLVED. IF YOU MUST WAIT FOR THE FOLLOWING WORKDAY TO CALL B.E.A., LEAVE THE DOOR INOPERABLE UNTIL SATISFACTORY REPAIRS CAN BE MADE. NEVER SACRIFICE THE SAFE OPERATION OF THE AUTOMATIC DOOR OR GATE FOR AN INCOMPLETE SOLUTION. WEB: WWW.BEASENSORS.COM

100 ENTERPRISE DRIVE
PITTSBURGH, PA 15275
PHONE: (412) 249-4100
FAX: (412) 249-4101
EMAIL: www.beasensors.com

TITLE: HORTON 4190 LO-LINX SYSTEM

SIZE: A	DRAWN BY: JED	REV BY: TUC	PART NO: 80.0284.00
SCALE: NONE	DATE: 10/15/2007	SHEET: 1 OF 1	

LO-LINX SWING	GREEN ACT.	WHITE COM.	YELLOW SAF.	BLUE STALL	BROWN STAL COM.
BESAM 300	13	12	11	15, 17	16, 8
BESAM M/P	3	4	9	5	4
DOM	YELLOW	GREY	BLUE	PURPLE	GREY
GT 300/400	BLACK	WHITE	RED	RED	WHITE
GT MAG	6 BLACK	5 RED	4 WHITE	3 VIOLET	5 RED
HORTON 490	2	3, 6, 8	4	10	3, 6, 8
HUNTER	ACT.	RTN	SAF. 1	SAF. 2	RTN
KM K	GREEN	WHITE	RED	YELLOW	WHITE
STANLEY "L"	ORANGE	YELLOW	RED	BLUE	YELLOW
STANLEY M/P	2	18	7	7	18
STANLEY 521	TB4-5	TB4-4	TB4-8	TB4-10	TB4-9
TORMAX TDA	2	1, 3, 6, 8	8 & 9	7	1, 3, 6, 8

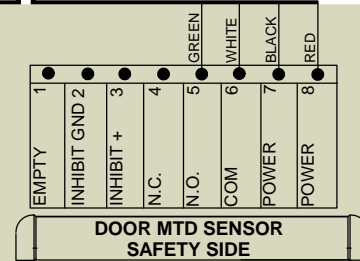
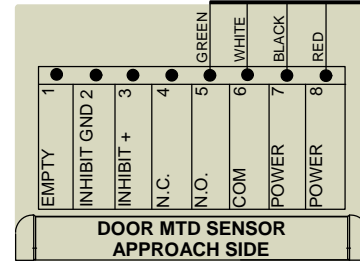
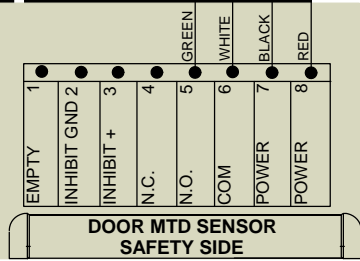
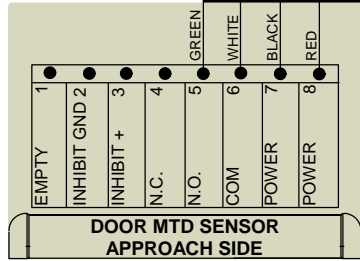
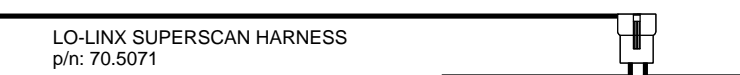
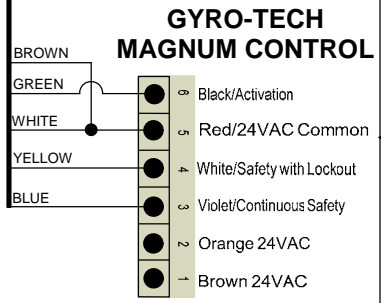
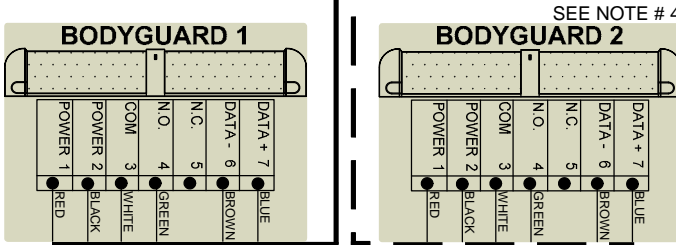
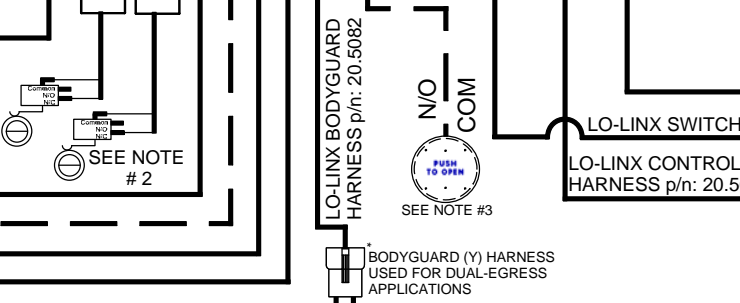
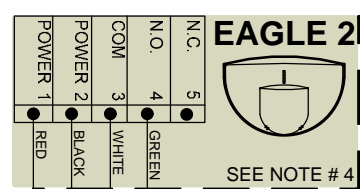
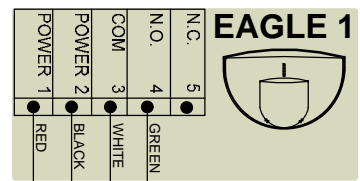
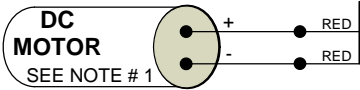
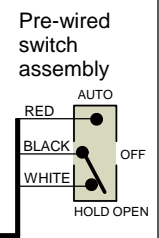
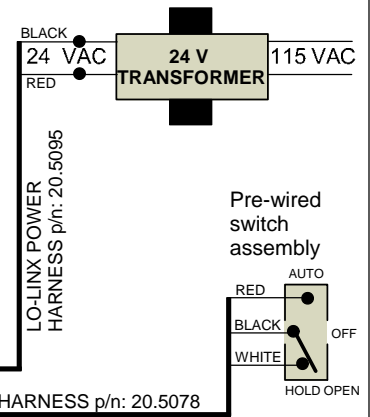
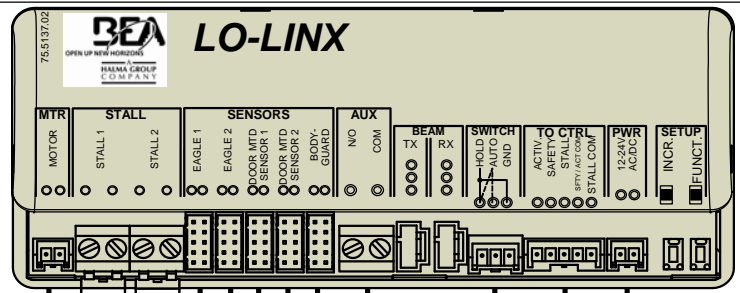

- NOTES:
1. MOTOR CONNECTION IS TIED IN PARALLEL TO EXISTING MOTOR LEADS. NO RESPECT TO PALARITY IS REQUIRED.
 2. EXTERNAL SWITCHES ARE REQUIRED IF INHIBIT DESIRED AT SWING SIDE SUPERSCANS, SWITCH OPENS UPON INHIBIT POINT.
 3. THE KNOWING ACT SWITCH IS CONNECTED AT THE AUX INPUT AND CAN BE ANY DRY CONTACT DEVICE SUCH AS A PUSHPLATE, CARD READER, ETC. THE AUX INPUT IS REQUIRED FOR ALL INITIAL ACTIVATION WHEN FUNCTION 'FA' ON THE LO-LINX IS SET TO '01'.
 4. THE SECOND BODYGUARD AND EAGLE ARE PRIMARILY USED IN DUAL-EGRESS APPLICATIONS. ENSURE BODYGUARD RELAY VALUE IS SET TO 2.

IF AFTER TROUBLESHOOTING A PROBLEM, A SATISFACTORY SOLUTION CANNOT BE ACHIEVED, PLEASE CALL B.E.A., INC. FOR FURTHER ASSISTANCE DURING EASTERN STANDARD TIME AT 1-800-523-2462 FROM 8AM - 5PM. FOR AFTER-HOURS, CALL EAST COAST: 1-866-836-1863 OR 1-800-407-4545 / MID-WEST: 1-888-308-8843 / WEST COAST: 1-888-419-2564. DO NOT LEAVE ANY PROBLEM UNRESOLVED. IF YOU MUST WAIT FOR THE FOLLOWING WORKDAY TO CALL B.E.A., LEAVE THE DOOR INOPERABLE UNTIL SATISFACTORY REPAIRS CAN BE MADE. NEVER SACRIFICE THE SAFE OPERATION OF THE AUTOMATIC DOOR OR GATE FOR AN INCOMPLETE SOLUTION. WEB: WWW.BEASENSORS.COM

BEA
OPEN UP NEW HORIZONS
HALMA GROUP COMPANY

100 ENTERPRISE DRIVE
PITTSBURGH, PA 15275
PHONE: (412) 249-4100
FAX: (412) 249-4101
EMAIL: www.beasensors.com

TITLE: GYROTECH MAGNUM CONTROL LO-LINX SYSTEM

SIZE: A	DRAWN BY: JED	REV BY: TUC	PART NO: 80.0283.00
SCALE: NONE	DATE: 10/15/2007	SHEET 1 OF 1	

LO-LINX SWING	GREEN ACT.	WHITE COM.	YELLOW SAF.	BLUE STALL	BROWN STAL COM.
BESAM 300	13	12	11	15, 17	16, 18
BESAM M/P	3	4	9	5	13
DOM	YELLOW	GREY	BLUE	PURPLE	GREY
GT 300/400	BLACK	RED	WHITE	WHITE	RED
GT MAG	6 BLACK	5 RED	4 WHITE	3 VIOLET	5 RED
HORTON 490	2	3, 6, 8	4	10	3, 6, 8
HUNTER	ACT.	RTN	SAF. 1	SAF. 2	RTN
KM K	GREEN	WHITE	RED	YELLOW	WHITE
STANLEY "L"	ORANGE	YELLOW	RED	BLUE	YELLOW
STANLEY M/P	2	1, 8	7	7	1, 8
STANLEY 521	TB4-5	TB4-4	TB4-8	TB4-10	TB4-9
TORMAXTDA	2	1, 3, 6, 8	8 & 9	7	1, 3, 6, 8

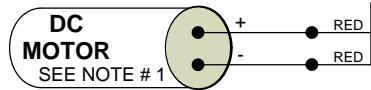
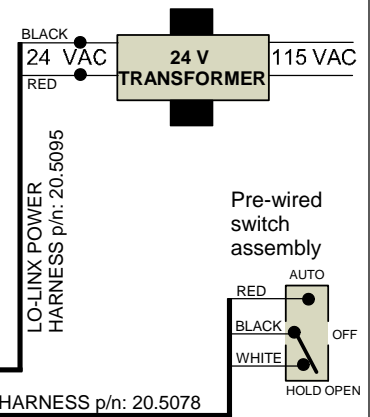
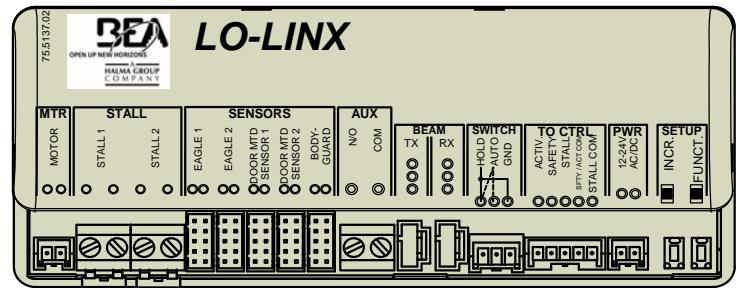

LO-LINX MOTOR HARNESS p/n: 20.5076

SEE NOTE #2

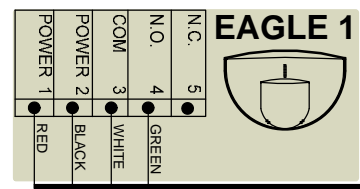

LO-LINX EAGLE HARNESS p/n: 20.5096

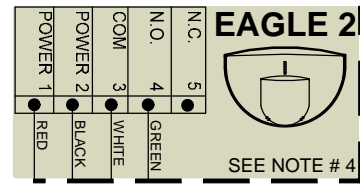

SEE NOTE #4

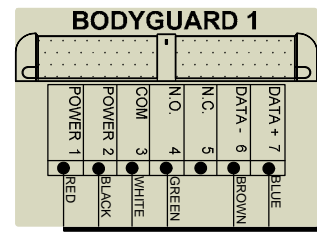

SEE NOTE #3

BODYGUARD (Y) HARNESS USED FOR DUAL-EGRESS APPLICATIONS

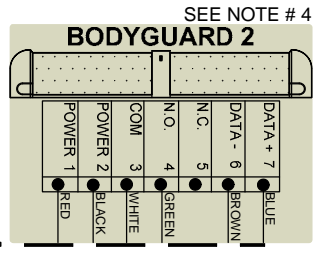

SEE NOTE #4

LO-LINX SUPERSCAN HARNESS p/n: 70.5071

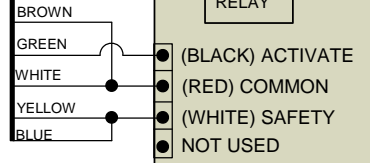
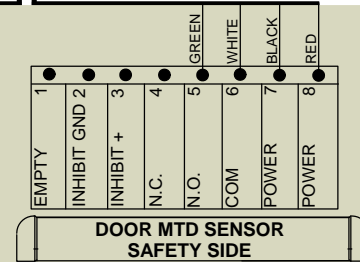
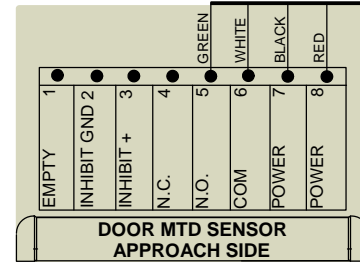
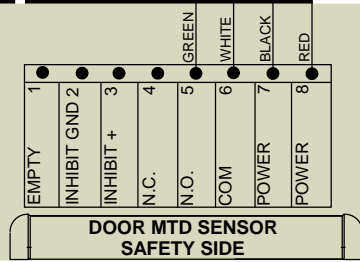
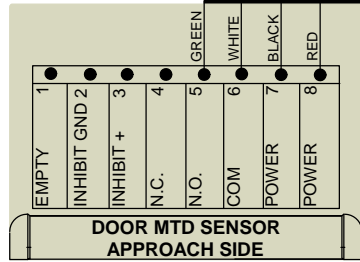

- NOTES:
1. MOTOR CONNECTION IS TIED IN PARALLEL TO EXISTING MOTOR LEADS. NO RESPECT TO PALARITY IS REQUIRED.
 2. EXTERNAL SWITCHES ARE REQUIRED IF INHIBIT DESIRED AT SWING SIDE SUPERSCANS, SWITCH OPENS UPON INHIBIT POINT.
 3. THE KNOWING ACT SWITCH IS CONNECTED AT THE AUX INPUT AND CAN BE ANY DRY CONTACT DEVICE SUCH AS A PUSHPLATE, CARD READER, ETC. THE AUX INPUT IS REQUIRED FOR ALL INITIAL ACTIVATION WHEN FUNCTION 'FA' ON THE LO-LINX IS SET TO '01'.
 4. THE SECOND BODYGUARD AND EAGLE ARE PRIMARILY USED IN DUAL-EGRESS APPLICATIONS. ENSURE BODYGUARD RELAY VALUE IS SET TO 2.
 5. SET DOOR CONTROL SLIDE SWITCH TO SWING SAFE.

IF AFTER TROUBLESHOOTING A PROBLEM, A SATISFACTORY SOLUTION CANNOT BE ACHIEVED, PLEASE CALL B.E.A., INC. FOR FURTHER ASSISTANCE DURING EASTERN STANDARD TIME AT 1-800-523-2462 FROM 8AM - 5PM. FOR AFTER-HOURS, CALL EAST COAST: 1-866-836-1863 OR 1-800-407-4545 / MID-WEST: 1-888-308-8843 / WEST COAST: 1-888-419-2564. DO NOT LEAVE ANY PROBLEM UNRESOLVED. IF YOU MUST WAIT FOR THE FOLLOWING WORKDAY TO CALL B.E.A., LEAVE THE DOOR INOPERABLE UNTIL SATISFACTORY REPAIRS CAN BE MADE. NEVER SACRIFICE THE SAFE OPERATION OF THE AUTOMATIC DOOR OR GATE FOR AN INCOMPLETE SOLUTION.WEB: WWW.BEASENSORS.COM

BEA
OPEN UP NEW HORIZONS
HALMA GROUP COMPANY

100 ENTERPRISE DRIVE
PITTSBURGH, PA 15275
PHONE: (412) 249-4100
FAX: (412) 249-4101
EMAIL: www.beasensors.com

TITLE: GYROTECH ANALOG 300-400 LO-LINX SYSTEM

SIZE: A	DRAWN BY: JED	REV BY: TUC	PART NO: 80.0282.00
SCALE: NONE	DATE: 10/15/2007	SHEET 1 OF 1	

LO-LINX SWING	GREEN ACT.	WHITE COM.	YELLOW SAF.	BLUE STALL	BROWN STAL COM.
BESAM 300	13	12	11	15, 17	16, 18
BESAM M/P	3	4	9	5	13
DOM	YELLOW	GREY	BLUE	PURPLE	GREY
GT 300/400	BLACK	RED	WHITE	WHITE	RED
GT MAG	6 BLACK	5 RED	4 WHITE	3 VIOLET	5 RED
HORTON 4190	2	3, 6, 8	4	10	3, 6, 8
HUNTER	ACT.	RTN	SAF. 1	SAF. 2	RTN
KM K	GREEN	WHITE	RED	YELLOW	WHITE
STANLEY "L"	ORANGE	YELLOW	RED	BLUE	YELLOW
STANLEY M/P	2	1, 8	7	7	1, 8
STANLEY 521	TB4-5	TB4-4	TB4-8	TB4-10	TB4-9
TORMAXTDA	2	1, 3, 6, 8	8 & 9	7	1, 3, 6, 8

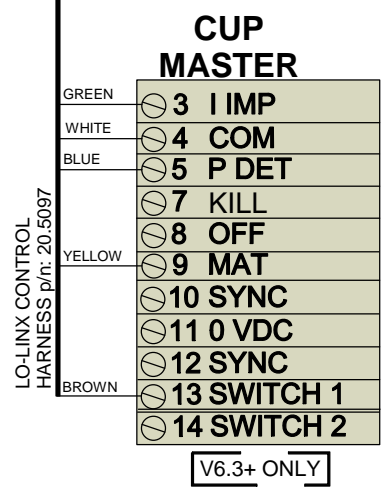
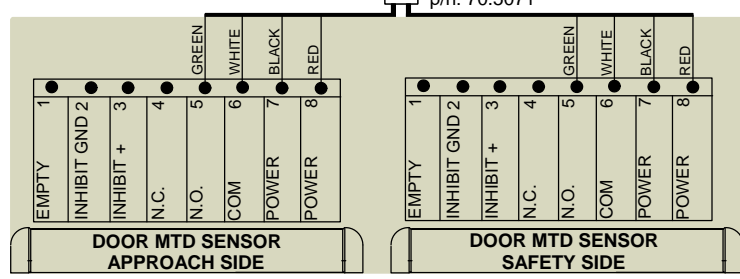
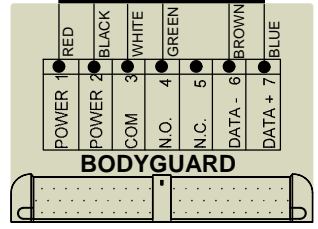
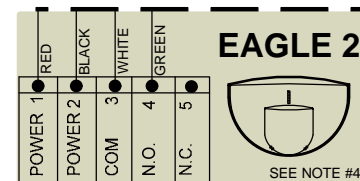
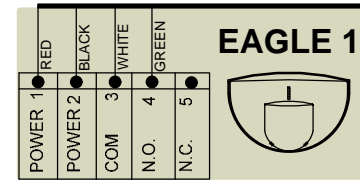
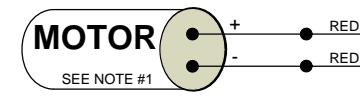
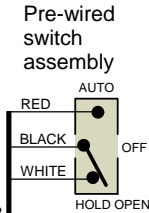
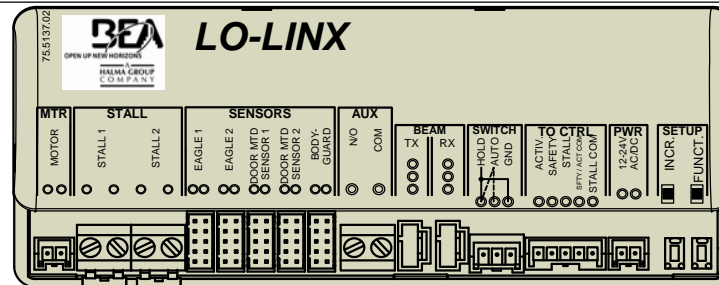

NOTES:

1. MOTOR CONNECTION IS TIED IN PARALLEL TO EXISTING MOTOR LEADS. NO RESPECT TO PALARITY IS REQUIRED.
2. THE KNOWING ACT SWITCH IS CONNECTED AT THE AUX INPUT AND CAN BE ANY DRY CONTACT DEVICE SUCH AS A PUSHPLATE, CARD READER, ETC. THE AUX INPUT IS REQUIRED FOR ALL INITIAL ACTIVATION WHEN FUNCTION 'FA' ON THE LO-LINX IS SET TO '01'.
3. SET CONTROL FUNCTION WITH PMD 13=a, 14=a, 16=0, 17=0, 18=0, 19=b, 20=a. F11= DEGREE AT WHICH TO IHIBIT SWING SIDE SUPERSCAN DEPENDING ON APPLICATION 65-75 DEGREES TYPICAL.
4. THE SECOND EAGLE IS PRIMARILY USED FOR TWO WAY TRAFFIC APPLICATIONS. ENSURE THE BODYGUARD RELAY VALUE IS SET TO 2.

IF AFTER TROUBLESHOOTING A PROBLEM, A SATISFACTORY SOLUTION CANNOT BE ACHIEVED, PLEASE CALL B.E.A., INC. FOR FURTHER ASSISTANCE DURING EASTERN STANDARD TIME AT 1-800-523-2462 FROM 8AM - 5PM. FOR AFTER-HOURS, CALL EAST COAST: 1-866-836-1863 OR 1-800-407-4545 / MID-WEST: 1-888-308-8843 / WEST COAST: 1-888-419-2564. DO NOT LEAVE ANY PROBLEM UNRESOLVED. IF YOU MUST WAIT FOR THE FOLLOWING WORKDAY TO CALL B.E.A., LEAVE THE DOOR INOPERABLE UNTIL SATISFACTORY REPAIRS CAN BE MADE. NEVER SACRIFICE THE SAFE OPERATION OF THE AUTOMATIC DOOR OR GATE FOR AN INCOMPLETE SOLUTION. WEB: WWW.BEASENSORS.COM

BEA
OPEN UP NEW HORIZONS
HALMA GROUP COMPANY

100 ENTERPRISE DRIVE
PITTSBURGH, PA 15275
PHONE: (412) 249-4100
FAX: (412) 249-4101
EMAIL: www.beasensors.com

TITLE: BESAM SINGLE CUP/MP V.6.3+ LO-LINX SYSTEM

SIZE: A	DRAWN BY: JED	REV BY: TUC	PART NO: 80.0281.00
SCALE: NONE	DATE: 10/15/2007	SHEET 1 OF 1	

LO-LINX SWING	GREEN ACT.	WHITE COM.	YELLOW SAF.	BLUE STALL	BROWN STAL COM.
BESAM 300	13	12	11	15, 17	16, 18
BESAM M/P	3	4	9	5	13
DOM	YELLOW	GREY	BLUE	PURPLE	GREY
GT 300/400	BLACK	RED	WHITE	WHITE	RED
GT MAG	6 BLACK	5 RED	4 WHITE	3 VIOLET	5 RED
HORTON 4190	2	3, 6, 8	4	10	3, 6, 8
HUNTER	ACT.	RTN	SAF. 1	SAF. 2	RTN
KM K	GREEN	WHITE	RED	YELLOW	WHITE
STANLEY "L"	ORANGE	YELLOW	RED	BLUE	YELLOW
STANLEY M/P	2	1, 8	7	7	1, 8
STANLEY 521	TB4-5	TB4-4	TB4-8	TB4-10	TB4-9
TORMAXTDA	2	1, 3, 6, 8	8 & 9	7	1, 3, 6, 8

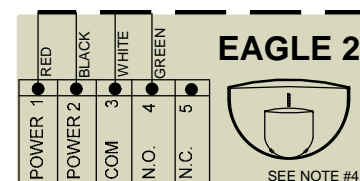
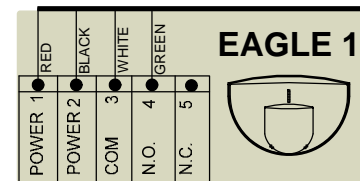
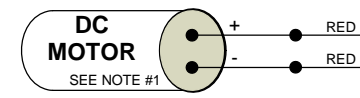
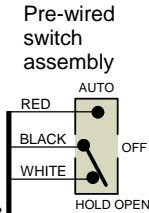
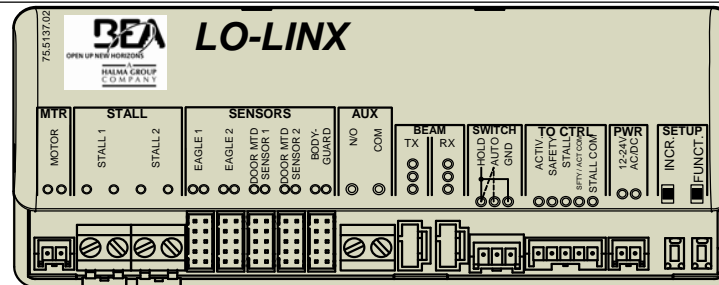

* BODYGUARD (Y) HARNESS USED FOR DUAL-EGRESS APPLICATIONS

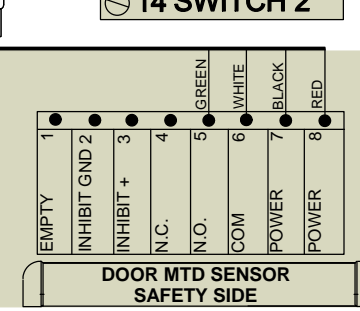
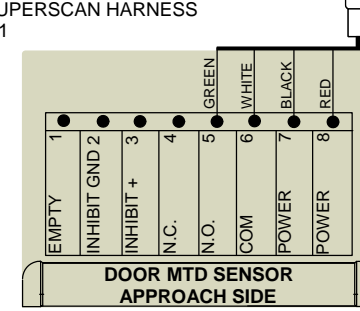
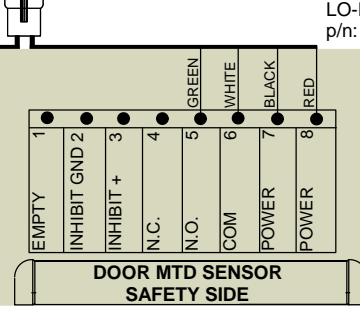
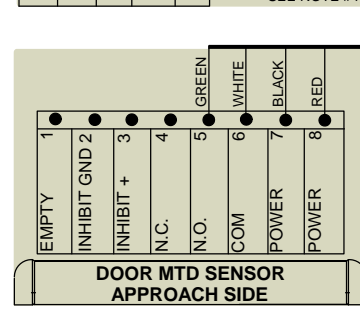
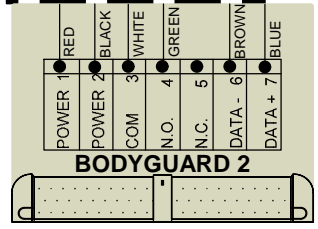
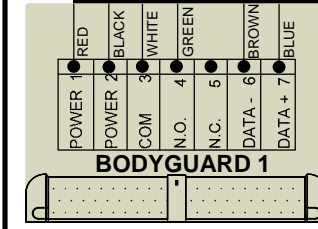

- NOTES:
1. MOTOR CONNECTION IS TIED IN PARALLEL TO EXISTING MOTOR LEADS. NO RESPECT TO PARALITY IS REQUIRED.
 2. THE KNOWING ACT SWITCH IS CONNECTED AT THE AUX INPUT AND CAN BE ANY DRY CONTACT DEVICE SUCH AS A PUSHPLATE, CARD READER, ETC. THE AUX INPUT IS REQUIRED FOR ALL INITIAL ACTIVATION WHEN FUNCTION 'FA' ON THE LO-LINX IS SET TO '01'.
 3. SET CONTROL FUNCTION WITH PMD 13=a,14=a,16=0,17=0,18=0,19=b,20=a. F11= DEGREE AT WHICH TO IHIBIT SWING SIDE SUPERSCAN DEPENDING ON APPLICATION 65-75 DEGREES TYPICAL.
 4. THE SECOND BODYGUARD AND EAGLE ARE PRIMARILY USED IN DUAL-EGRESS APPLICATIONS. ENSURE TO SET THE BODYGUARD RELAY VALUE TO 2.

IF AFTER TROUBLESHOOTING A PROBLEM, A SATISFACTORY SOLUTION CANNOT BE ACHIEVED, PLEASE CALL B.E.A., INC. FOR FURTHER ASSISTANCE DURING EASTERN STANDARD TIME AT 1-800-523-2462 FROM 8AM - 5PM. FOR AFTER-HOURS, CALL EAST COAST: 1-866-836-1863 OR 1-800-407-4545 / MID-WEST: 1-888-308-8843 / WEST COAST: 1-888-419-2564. DO NOT LEAVE ANY PROBLEM UNRESOLVED. IF YOU MUST WAIT FOR THE FOLLOWING WORKDAY TO CALL B.E.A., LEAVE THE DOOR INOPERABLE UNTIL SATISFACTORY REPAIRS CAN BE MADE. NEVER SACRIFICE THE SAFE OPERATION OF THE AUTOMATIC DOOR OR GATE FOR AN INCOMPLETE SOLUTION. WEB: WWW.BEASENSORS.COM

BEA
OPEN UP NEW HORIZONS

HALMA GROUP COMPANY

100 ENTERPRISE DRIVE
PITTSBURGH, PA 15275
PHONE: (412) 249-4100
FAX: (412) 249-4101
EMAIL: www.beasensors.com

TITLE: BESAM DUAL CUP/MP V.6.3+ LO-LINX SYSTEM

SIZE: A	DRAWN BY: JED	REV BY: TUC	PART NO: 80.0280.00
SCALE: NONE	DATE: 10/15/2007	SHEET 1 OF 1	

LO-LINX SWING	GREEN ACT.	WHITE COM.	YELLOW SAF.	BLUE STALL	BROWN STAL COM.
BESAM 300	13	12	11	15, 17	16, 18
BESAM M/P	3	4	9	5	13
DOM	YELLOW	GREY	BLUE	PURPLE	GREY
GT 300/400	BLACK	RED	WHITE	WHITE	RED
GT MAG	6 BLACK	5 RED	4 WHITE	3 VIOLET	5 RED
HORTON 4190	2	3, 6, 8	4	10	3, 6, 8
HUNTER	ACT.	RTN	SAF. 1	SAF. 2	RTN
KM K	GREEN	WHITE	RED	YELLOW	WHITE
STANLEY "L"	ORANGE	YELLOW	RED	BLUE	YELLOW
STANLEY M/P	2	1, 8	7	7	1, 8
STANLEY 521	TB4-5	TB4-4	TB4-8	TB4-10	TB4-9
TORMAX TDA	2	1, 3, 6, 8	8 & 9	7	1, 3, 6, 8

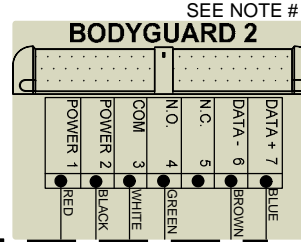
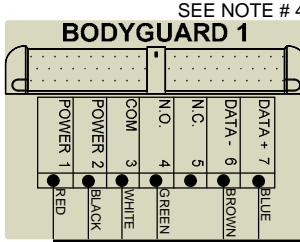
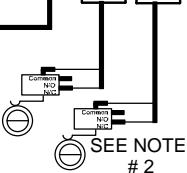
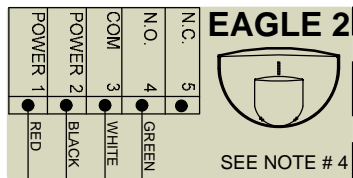
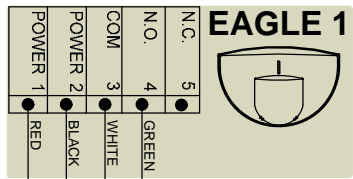
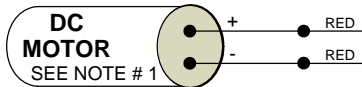
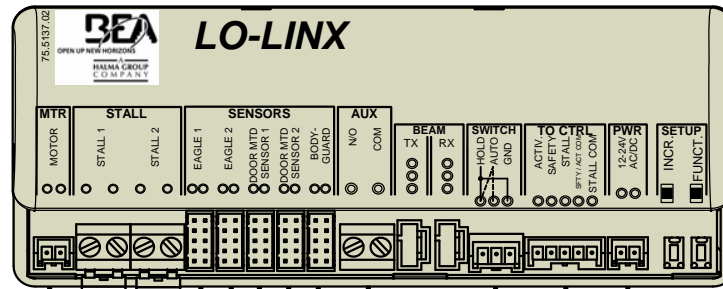

① IN	OFF
② GND	AUTO
③ IN	OPEN
④ GND	
⑤ IN	ACT.
⑥ 24+	
⑦ GND	
⑧ IN	
⑨ OUT	
⑩ 24+	
⑪ OUT	DOOR STATUS
⑫ 24V+V	
⑬ GND	
⑭ IN	SWING
⑮ OUT	SIDE SAFETY
⑯ GND	
⑰ IN	BODYGUARD
⑱ OUT	SAFETY
⑳ +24V	

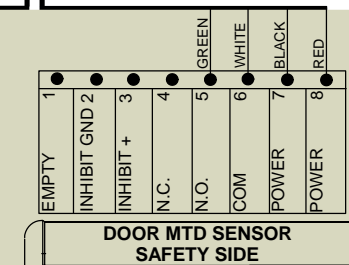
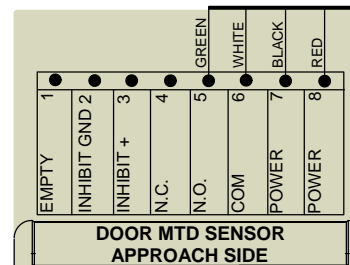
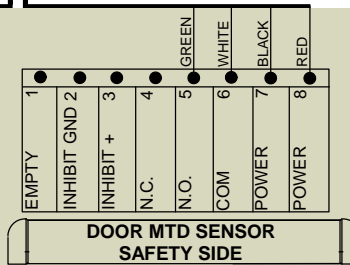
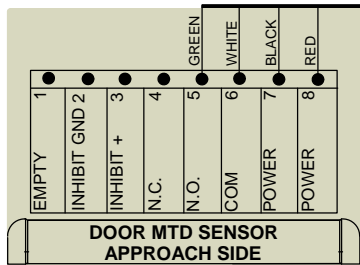

- NOTES:
1. MOTOR CONNECTION IS TIED IN PARALLEL TO EXISTING MOTOR LEADS. NO RESPECT TO PALARITY IS REQUIRED.
 2. EXTERNAL SWITCHES ARE REQUIRED IF INHIBIT DESIRED AT SWING SIDE SUPERSkans, SWITCH OPENS UPON INHIBIT POINT.
 3. THE KNOWING ACT SWITCH IS CONNECTED AT THE AUX INPUT AND CAN BE ANY DRY CONTACT DEVICE SUCH AS A PUSHPLATE, CARD READER, ETC. THE AUX INPUT IS REQUIRED FOR ALL INITIAL ACTIVATION WHEN FUNCTION 'FA' ON THE LO-LINX IS SET TO '01'.
 4. THE SECOND BODYGUARD AND EAGLE ARE PRIMARILY USED IN DUAL-EGRESS APPLICATIONS. ENSURE BODYGUARD RELAY VALUE IS SET TO 2.

IF AFTER TROUBLESHOOTING A PROBLEM, A SATISFACTORY SOLUTION CANNOT BE ACHIEVED, PLEASE CALL B.E.A., INC. FOR FURTHER ASSISTANCE DURING EASTERN STANDARD TIME AT 1-800-523-2462 FROM 8AM - 5PM. FOR AFTER-HOURS, CALL EAST COAST: 1-866-836-1863 OR 1-800-407-4545 / MID-WEST: 1-888-308-8843 / WEST COAST: 1-888-419-2564. DO NOT LEAVE ANY PROBLEM UNRESOLVED. IF YOU MUST WAIT FOR THE FOLLOWING WORKDAY TO CALL B.E.A., LEAVE THE DOOR INOPERABLE UNTIL SATISFACTORY REPAIRS CAN BE MADE. NEVER SACRIFICE THE SAFE OPERATION OF THE AUTOMATIC DOOR OR GATE FOR AN INCOMPLETE SOLUTION. WEB: WWW.BEASENSORS.COM

BEA
OPEN UP NEW HORIZONS
A HALMA GROUP COMPANY

100 ENTERPRISE DRIVE
PITTSBURGH, PA 15275
PHONE: (412) 249-4100
FAX: (412) 249-4101
EMAIL: www.beasensors.com

TITLE: TORMAX-TTXII LO-LINX SYSTEM

SIZE: A	DRAWN BY: JED	REV BY: TUC	PART NO: 80.0289.00
SCALE: NONE	DATE: 10/15/2007	SHEET 1 OF 1	